



2013
FUSION HYBRID
MKZ HYBRID
FUSION ENERGI



HIGH-VOLTAGE BATTERY REMOVAL GUIDE

Table of Contents

FOREWORD	Page 2
ELECTRIC VEHICLE IDENTIFICATION	Page 3
VIN Layout	Page 4
HIGH-VOLTAGE ELECTRICAL DISCONNECT FEATURES	Page 5
HIGH-VOLTAGE WARNING DECALS	Page 6
HYBRID COMPONENT LOCATION AND IDENTIFICATION	Page 7-8
ENERGI COMPONENT LOCATION AND IDENTIFICATION	Pages 9-10
HIGH-VOLTAGE SERVICE DISCONNECTS	Page 11
HIGH-VOLTAGE BATTERY PACKS	Pages 11-12
APPROACHING A DAMAGED HIGH-VOLTAGE VEHICLE	Page 13
Follow Existing Training and Incident Commander Direction	Page 13
Approaching a Damaged Vehicle	Pages 14-15
If The High-Voltage Battery Case Has Been Ruptured	Page 15
Moving Damaged Vehicles - Wrecker Drivers	Page 15
Special Note To Salvage Yards	Page 15
High Voltage System - Do Not Cut Zones	Page 16
DAMAGED VEHICLE GUIDANCE FOR FORD MOTOR COMPANY ELECTRIC AND HYBRID-ELECTRIC VEHICLES EQUIPPED WITH HIGH VOLTAGE BATTERIES	Pages 17-19
HIGH VOLTAGE BATTERY REMOVAL	Pages 20-36
SPECIAL NOTE TO SALVAGE YARDS	Pages 37-38

FOREWORD

The emergency response procedures for the Fusion Hybrid, MKZ Hybrid and Fusion Energi vehicles are similar to those for traditional gasoline-powered vehicles with the addition of special considerations for the high-voltage electric system components.

The Fusion Hybrid, MKZ Hybrid and Fusion Energi vehicles use a conventional gasoline engine in addition to an electric motor to power the vehicle.

- Gasoline is stored in a traditional fuel tank.
- Electricity is stored in a high-voltage battery pack.

The combination of a gasoline engine and electric motor provides for improved performance (V6 performance with a 4-cylinder engine and electric motor), reduced emissions and improved fuel economy. The Fusion Hybrid and MKZ Hybrid high-voltage systems are self contained, never needing to be plugged into an electrical outlet for recharging. The Fusion Energi high-voltage system can be plugged into an electric outlet for recharging to optimize the vehicle's extended electrical range. Both vehicle systems incorporate a generator that charges the high-voltage battery during cruising and braking.

The information in this guide will allow response to emergencies involving the Fusion Hybrid, MKZ Hybrid and Fusion Energi vehicles to be as safe as non-hybrid vehicles.

The Fusion Hybrid, MKZ Hybrid and Fusion Energi vehicles have been designed with many safety features for your protection. These features help provide safe access to the vehicle under various conditions; however, when approaching a high-voltage vehicle in a fire, rescue or recovery situation, always follow one industry standard rule:

***ALWAYS ASSUME THE VEHICLE'S
HIGH-VOLTAGE SYSTEM IS POWERED UP !***

HYBRID / ENERGI VEHICLE IDENTIFICATION

- The Fusion Hybrid and MKZ Hybrid vehicles can easily be identified by the “Hybrid” badges located on the left and right front doors. There is a “Hybrid” nameplate on the trunk lid (located on the right hand side) that also includes the green leaf/blue highway “Hybrid” icon.



NOTE: Fusion Hybrid shown, MKZ Hybrid similar.

- The Fusion Energi vehicles can easily be identified by the “Energi” badges located on the left and right front doors. There is a “Energi” nameplate on the trunk lid (located on the left hand side) that also includes the green leaf/blue highway “Hybrid” icon.



NOTE: Fusion Energi shown.

Hybrid/Energi nameplate and icon on trunk lid.

Hybrid/Energi nameplate with Hybrid icon on front doors.



- The Fusion Hybrid and MKZ Hybrid vehicles have a unique engine appearance cover with a raised “HYBRID” icon on it.

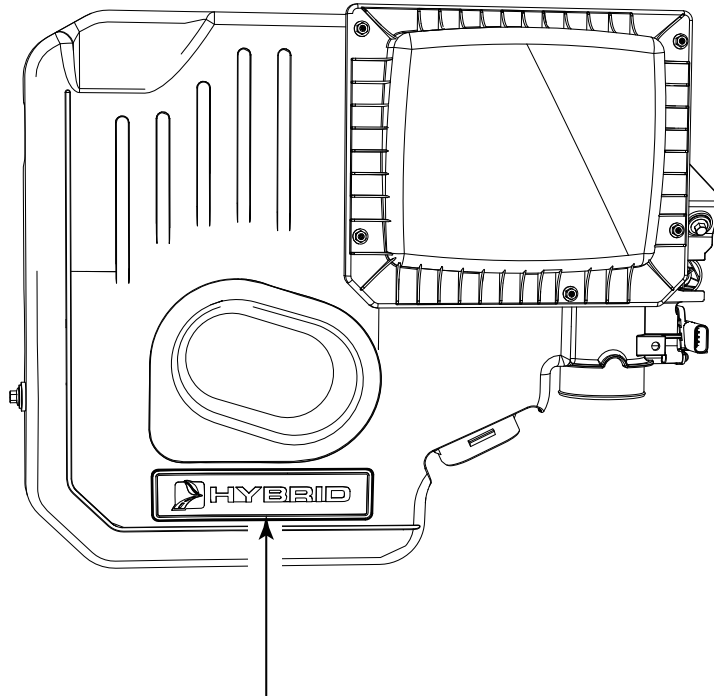

Unique Hybrid engine appearance cover with raised lettering and icon

NOTE: Fusion/MKX Hybrid shown, Fusion Energi similar.

- The 5th, 6th and 7th digits of the Vehicle Identification Number (VIN) identify the Hybrid vehicle line.

VIN POSITIONS 5, 6 and 7	
P0L	Fusion SE Full Hybrid
L2L	MKZ Hybrid Full Hybrid
P0P	Fusion SE Energi Plug-in Hybrid
P0R	Fusion Titanium Full Hybrid
P0S	Fusion Titanium Energi Plug In Hybrid

SAMPLE VIN

3 F A D P 0 L 3 0 A R 1 0 0 0 0 1



Fusion Hybrid FWD

HIGH-VOLTAGE ELECTRICAL DISCONNECT FEATURES



WARNING: ELECTRIC VEHICLES DAMAGED BY A CRASH MAY HAVE COMPROMISED HIGH-VOLTAGE SAFETY SYSTEMS AND PRESENT A POTENTIAL HIGH-VOLTAGE ELECTRICAL SHOCK HAZARD. EXERCISE CAUTION AND WEAR APPROPRIATE PERSONAL PROTECTIVE EQUIPMENT (PPE) SAFETY GEAR, INCLUDING HIGH-VOLTAGE SAFETY GLOVES AND BOOTS. REMOVE ALL METALLIC JEWELRY, INCLUDING WATCHES AND RINGS. ISOLATE THE HV SYSTEM AS DIRECTED BY THE FORD EMERGENCY RESPONSE GUIDE FOR THE VEHICLE. FAILURE TO FOLLOW THESE INSTRUCTIONS MAY RESULT IN SERIOUS PERSONAL INJURY OR DEATH.

The following list describes certain features that have been incorporated into the Fusion Hybrid, MKZ Hybrid and Fusion Energi vehicles that allow for either simple or automatic shut off of the high-voltage electrical systems.

- High-Voltage Fuse — In the event of a high-voltage short circuit, the high-voltage fuse will open, disabling the high-voltage system.
- High-Voltage Interlock Circuit — Whenever a high-voltage connector is disconnected, the high-voltage interlock circuit opens and disables the high-voltage system.
- Ignition Key/Button in the OFF Position — Any time the ignition is in the OFF position, the high-voltage system is disabled.

NOTE: If the vehicle is equipped with remote start, high-voltage may be present in the system if the ignition is off.

NOTE: ENERGI vehicles, when plugged in for charging may have high-voltage present in the system if the ignition is off.

- High-Voltage Service Disconnect — Whenever the high-voltage service disconnect (located behind the rear seat back) is removed, the high-voltage system is disabled. For additional information, refer to Page 11 in this manual.
- Thermal Sensors — In the event the battery is exposed to extreme hot ambient conditions and/or is being driven extremely aggressively with compromised cooling, power limits will be employed to prevent overheating. However, if the battery is in use and does become too hot, contactors will be opened and the vehicle will shut down. In some instances, if the ignition key is left in the “ON” position, this could cause the high-voltage battery temperature to exceed 60°C (140°F); if this temperature is reached, the thermal sensors located near the high-voltage battery will automatically disable the high-voltage battery.

HIGH-VOLTAGE WARNING DECALS

- On Hybrid vehicles, WARNING decals are located on components in the high-voltage system throughout the vehicle. Please see example below.

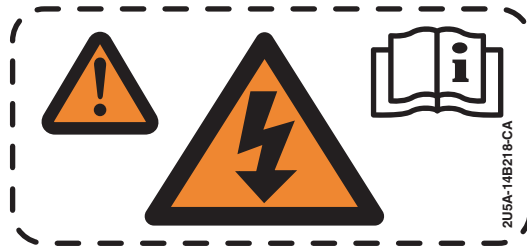

⚠ WARNING: HIGH VOLTAGE VEHICLE ⚠	
TO REDUCE THE RISK OF POSSIBLE SERIOUS INJURY (SHOCK OR BURN) OR DEATH: COMPONENTS MARKED WITH THE HIGH VOLTAGE SYMBOL ⚠ CONTAIN HIGH VOLTAGE AND HIGH TEMPERATURES AND SHOULD BE AVOIDED. SERVICE MUST BE PERFORMED BY QUALIFIED PERSONNEL ONLY. 📖	
⚠ AVERTISSEMENT : CIRCUITS HAUTE TENSION DU VÉHICULE ⚠	
POUR RÉDUIRE LES RISQUES DE BLESSURES GRAVES (CHOCS OU BRÛLURES) OU MORTELLES : LES ÉLÉMENTS ACCOMPAGNÉS DU SYMBOLE HAUTE TENSION ⚠ ONT UNE TENSION ET DES TEMPÉRATURES ÉLEVÉES ET DOIVENT ÊTRE ÉVITÉS. 📖	
LA RÉPARATION ET L'ENTRETIEN DOIVENT ÊTRE EFFECTUÉS PAR UN TECHNICIEN QUALIFIÉ SEULEMENT.	4L8A-14B218-AB

HYBRID COMPONENT LOCATION AND IDENTIFICATION

The illustration below and its defining chart on Page 8, provide the location, description and basic function of the Hybrid system components.

NOTE: All high-voltage wires and harnesses are wrapped in orange-colored insulation.

NOTE: Fusion Hybrid shown, MKZ Hybrid similar.

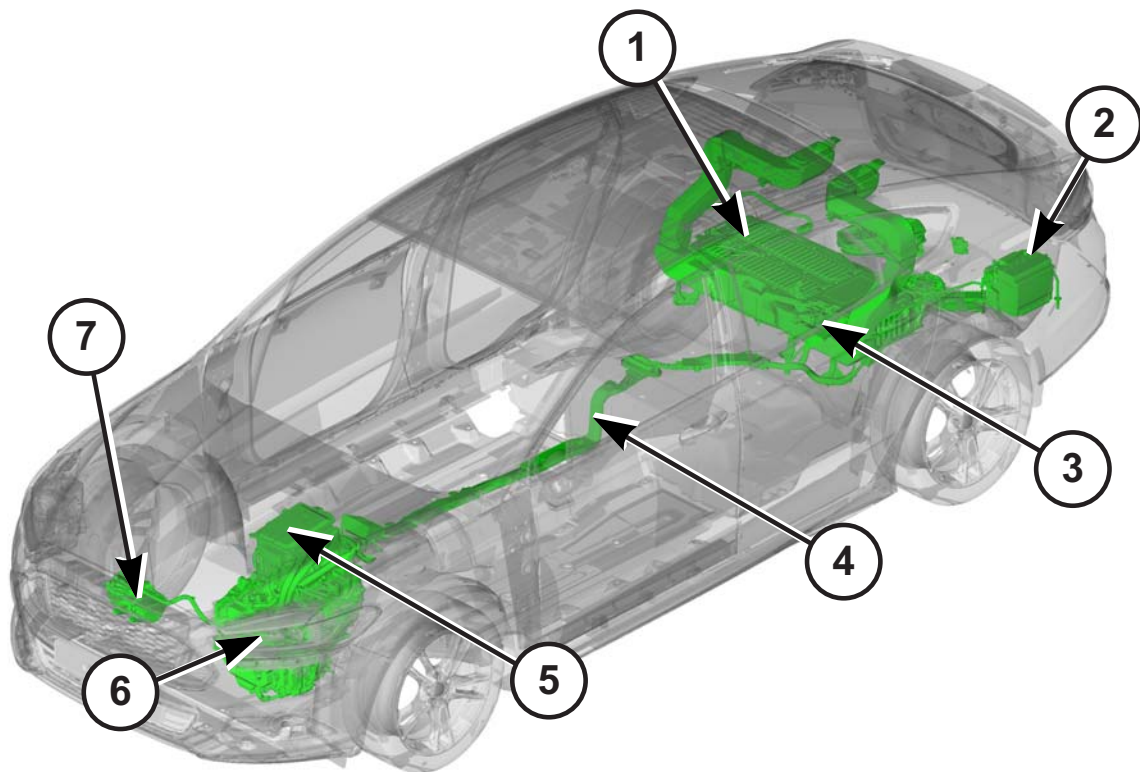

HYBRID COMPONENT LOCATION AND IDENTIFICATION - CONTINUED

	COMPONENT	LOCATION / DESCRIPTION	FUNCTION
1	High-Voltage Battery Approximately 300-Volts DC	<ul style="list-style-type: none"> • Lies flat in the trunk area, located behind the rear seat. • Sealed lithium battery. 	Provides high-voltage storage for vehicle's electric motor.
2	12-Volt Battery	<ul style="list-style-type: none"> • Located in the trunk area of the vehicle. • Typical automotive 6-cell lead/acid design. 	Provides 12-volts for vehicle accessories.
3	High-Voltage Service Disconnect	<ul style="list-style-type: none"> • Located behind the rear seatback. • Orange rectangle with a molded plastic handle, about 100 mm (4 in) in length. 	Provides means to disconnect high-voltage battery for safely servicing vehicle.
4	High-Voltage Wiring	<ul style="list-style-type: none"> • Runs along the vehicle's floorpan from the high-voltage battery to the Electronically Controlled Continuously Variable Transaxle (ECVT), to the DC-to-DC converter and then to the electric A/C and heater units. • All high-voltage wiring has orange-colored insulation. 	Provides physical connection between high-voltage battery and vehicle's high-voltage equipment.
5	Transmission Control Module	<ul style="list-style-type: none"> • Located above the transmission. • Contains controlling electronics for managing propulsion. 	Provides rotational force during Electrical Drive Modes. Generates 3-phase AC High Voltage electricity via two cables to and from the traction motor and generator.
6	Electronically Controlled Continuously Variable Transaxle (ECVT)	<ul style="list-style-type: none"> • Transverse-mounted design, similar to the non-Hybrid Fusion MKZ vehicles. 	Provides rotational force to the wheels for vehicle propulsion and transmits rotational force to the engine's generator to recharge batteries.
7	Electric A/C Compressor	<ul style="list-style-type: none"> • Located in front of the engine. • It has an orange high voltage wire attached to it using an interlock connector. 	Provides electric A/C operation; replaces the belt driven A/C compressor.

ENERGI COMPONENT LOCATION AND IDENTIFICATION

The illustration below and its defining chart on Page 10, provide the location, description and basic function of the Fusion Energi's system components.

NOTE: All high-voltage wires and harnesses are wrapped in orange-colored insulation.

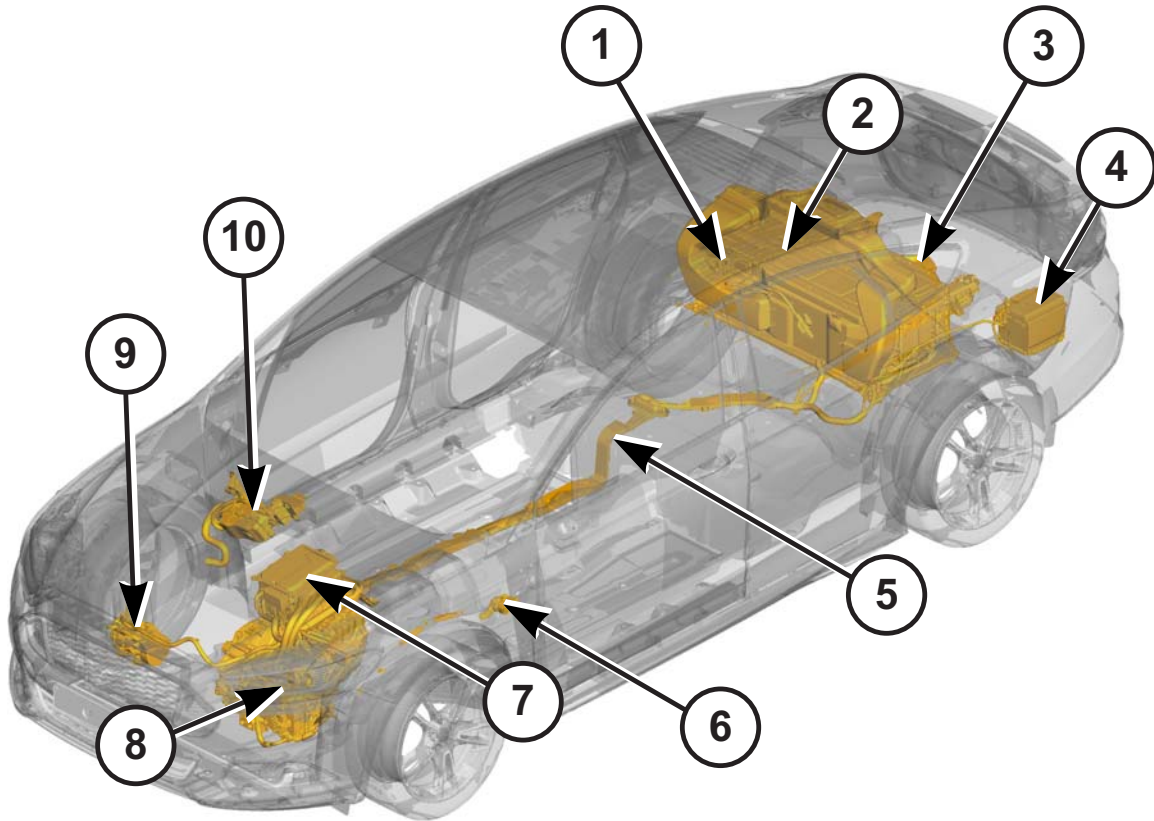

ENERGI COMPONENT LOCATION AND IDENTIFICATION - CONTINUED

	COMPONENT	LOCATION / DESCRIPTION	FUNCTION
1	High-Voltage Service Disconnect	<ul style="list-style-type: none"> • Located behind the rear seat back. • Orange rectangle with a molded plastic handle, about 100 mm (4 in) in length. 	Provides means to disconnect high-voltage battery for safely servicing vehicle.
2	High-Voltage Battery Approximately 300-Volts DC	<ul style="list-style-type: none"> • Lies flat in the trunk area, located behind the rear seat. • Sealed lithium battery. 	Provides high-voltage storage for vehicle's electric motor.
3	110-Volt Cordset	<ul style="list-style-type: none"> • Located in the trunk area of the vehicle. 	Provides 110v charging option to the high-voltage battery when connected to the charging port .
4	12-Volt Battery	<ul style="list-style-type: none"> • Located in the trunk area of the vehicle. • Typical automotive 6-cell lead/acid design. 	Provides 12-volts for vehicle accessories.
5	High-Voltage Wiring	<ul style="list-style-type: none"> • Runs along the vehicle's floorpan from the high-voltage battery to the Electronically Controlled Continuously Variable Transaxle (ECVT), to the DC-to-DC converter and then to the electric A/C and heater units. • All high-voltage wiring has orange-colored insulation. 	Provides physical connection between High-Voltage battery and vehicle's High-Voltage equipment.
6	Charging Port	<ul style="list-style-type: none"> • Located on the driver side fender. 	Provides 110v charging option to the high-voltage battery when the vehicle is not in operation .
7	Transmission Control Module	<ul style="list-style-type: none"> • Located above the transmission. • Contains controlling electronics for managing propulsion. 	Provides rotational force during Electrical Drive Modes. Generates 3-phase AC High Voltage electricity via two cables to and from the traction motor and generator.
8	Electronically Controlled Continuously Variable Transaxle (ECVT)	<ul style="list-style-type: none"> • Transverse-mounted design, similar to the non-Hybrid Fusion MKZ vehicles. 	Provides rotational force to the wheels for vehicle propulsion and transmits rotational force to the engine's generator to recharge batteries.
9	Electric A/C Compressor	<ul style="list-style-type: none"> • Located in front of the engine. • It has an orange high voltage wire attached to it using an interlock connector. 	Provides electric A/C operation; replaces the belt driven A/C compressor.
10	Electric Heater	<ul style="list-style-type: none"> • Located in the engine compartment on the passenger side. 	Provides passenger compartment with heat without the need to turn the engine on.

HIGH-VOLTAGE SERVICE DISCONNECT

NOTE: If possible, release and remove the high-voltage service disconnect.

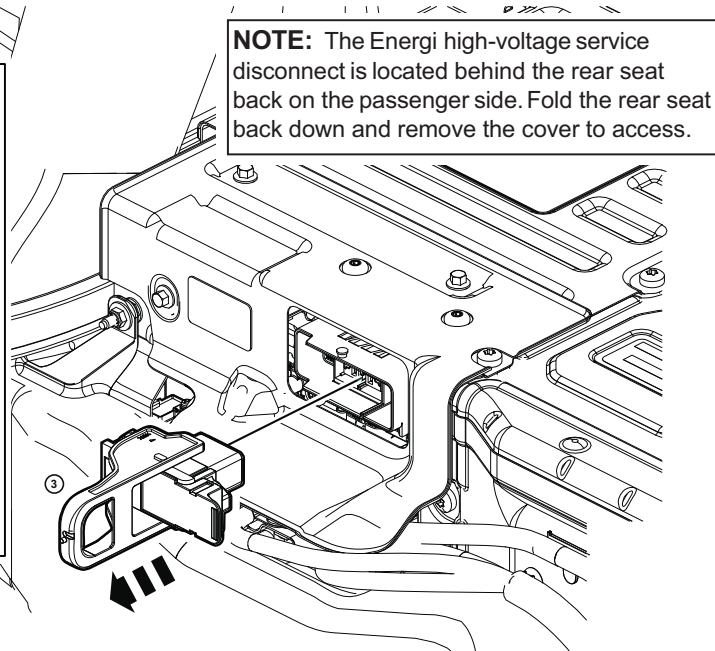
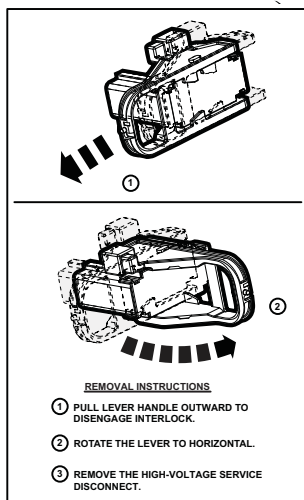
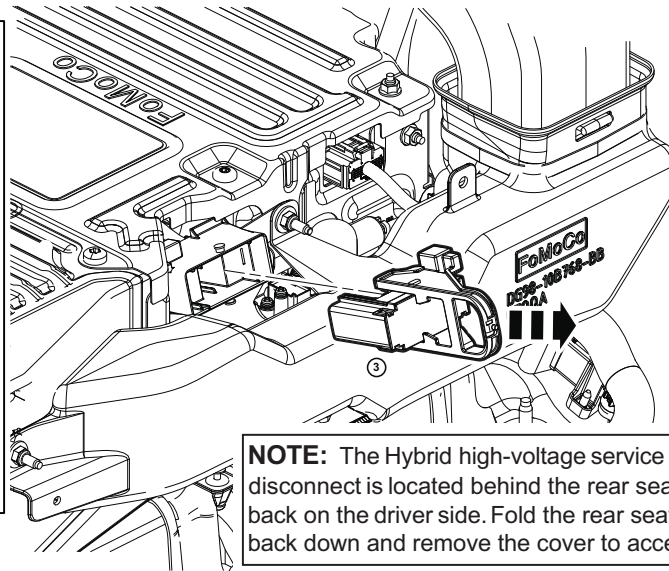
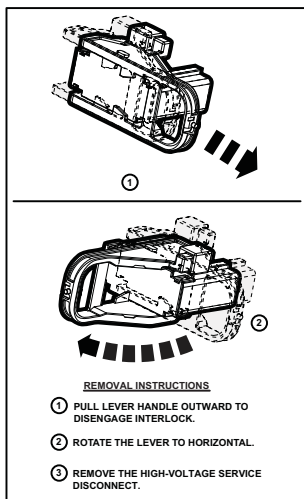

HIGH-VOLTAGE BATTERY PACK



WARNING: ELECTRIC VEHICLES DAMAGED BY A CRASH MAY HAVE COMPROMISED HIGH-VOLTAGE SAFETY SYSTEMS AND PRESENT A POTENTIAL HIGH-VOLTAGE ELECTRICAL SHOCK HAZARD. EXERCISE CAUTION AND WEAR APPROPRIATE PERSONAL PROTECTIVE EQUIPMENT (PPE) SAFETY GEAR, INCLUDING HIGH-VOLTAGE SAFETY GLOVES AND BOOTS. REMOVE ALL METALLIC JEWELRY, INCLUDING WATCHES AND RINGS. ISOLATE THE HV SYSTEM AS DIRECTED BY THE FORD EMERGENCY RESPONSE GUIDE FOR THE VEHICLE. FAILURE TO FOLLOW THESE INSTRUCTIONS MAY RESULT IN SERIOUS PERSONAL INJURY OR DEATH.

HIGH-VOLTAGE BATTERY PACKS - CONTINUED



WARNING: FIRES IN CRASH-DAMAGED ELECTRIC VEHICLES MAY EMIT TOXIC OR COMBUSTIBLE GASSES. SMALL AMOUNTS OF EYE, SKIN OR LUNG IRRITANTS MAY BE PRESENT. WEAR PERSONAL PROTECTIVE EQUIPMENT (PPE) AND SELF-CONTAINED BREATHING APPARATUS WHEN WORKING IN CLOSE PROXIMITY OR IN A CONFINED AREA, SUCH AS A TUNNEL OR GARAGE. VENTILATE THE VEHICLE INTERIOR BY OPENING VEHICLE WINDOWS OR DOORS. VENTILATE THE WORKING AREA. FAILURE TO FOLLOW THIS INSTRUCTION MAY RESULT IN SERIOUS PERSONAL INJURY OR DEATH.

- Do not cut the high-voltage battery case. Do not penetrate the batteries or case in any way.
- The high-voltage battery is located in the forward portion of the luggage compartment. The high-voltage battery lies flat just behind the rear seat back under the luggage compartment cargo cover.
- Removing the high-voltage service disconnect will disconnect the high-voltage from the vehicle. The battery pack will remain live and dangerous.
- The total voltage of the battery pack is approximately 300 volts DC.
- The battery cells contain a base electrolyte, consisting of lithium hexafluorophosphate and organic solvents as the dominant active ingredient, that is absorbed in special polymeric film. The electrolyte will not leak from the battery under most conditions, however, if the battery is crushed, it is possible for a small amount of electrolyte to leak.

NOTICE: The following must be followed when working with a damaged battery:

- If possible, isolate and avoid contact with high voltage vehicle components. If contact with the high voltage system cannot be avoided, Personal Protective Equipment (PPE) such as a splash shield or safety goggles, gloves (latex, rubber or Nitrile), an apron or overcoat and rubber boots are required when handling damaged batteries. Exposure to electrolyte could cause skin and/or eye irritation/burns. If exposed, rinse with large amounts of water for 10-15 minutes.
- If the battery is exposed to intense heat (or other abusive conditions), it is possible that flammable gases and liquid (electrolyte) have been released from the cells. The gases include combustible hydrocarbons such as methane, toxic gases such as carbon monoxide, and very small amounts of eye/skin/lung irritants such as hydrofluoric acid could be released from the battery. Appropriate precautions should be taken to make sure the area is properly ventilated, such as opening the vehicle's windows or doors. First responders should wear Personal Protective Equipment (PPE) and self contained breathing apparatus to safeguard against thermal, electrical, respiratory and skin/eye hazards.

APPROACHING A DAMAGED HIGH-VOLTAGE VEHICLE



WARNING: ELECTRIC VEHICLES DAMAGED BY A CRASH MAY HAVE COMPROMISED HIGH-VOLTAGE SAFETY SYSTEMS AND PRESENT A POTENTIAL HIGH-VOLTAGE ELECTRICAL SHOCK HAZARD. EXERCISE CAUTION AND WEAR APPROPRIATE PERSONAL PROTECTIVE EQUIPMENT (PPE) SAFETY GEAR, INCLUDING HIGH-VOLTAGE SAFETY GLOVES AND BOOTS. REMOVE ALL METALLIC JEWELRY, INCLUDING WATCHES AND RINGS. ISOLATE THE HV SYSTEM AS DIRECTED BY THE FORD EMERGENCY RESPONSE GUIDE FOR THE VEHICLE. FAILURE TO FOLLOW THESE INSTRUCTIONS MAY RESULT IN SERIOUS PERSONAL INJURY OR DEATH.



WARNING: DAMAGED ELECTRIC VEHICLES SUBMERGED IN WATER PRESENT A POTENTIAL HIGH VOLTAGE ELECTRICAL SHOCK HAZARD. EXERCISE CAUTION AND WEAR APPROPRIATE PERSONAL PROTECTIVE EQUIPMENT (PPE) SAFETY GEAR, INCLUDING HIGH VOLTAGE SAFETY GLOVES AND BOOTS. REMOVE ALL METALLIC JEWELRY, INCLUDING WATCHES AND RINGS. DO NOT ATTEMPT TO EXTRACT THE VEHICLE UNTIL THE HIGH VOLTAGE BATTERY HAS DISCHARGED INDICATED BY THE ABSENCE OF BUBBLING OR FIZZING. FAILURE TO FOLLOW THESE INSTRUCTIONS MAY RESULT IN SERIOUS PERSONAL INJURY OR DEATH.

1. FOLLOW EXISTING TRAINING AND INCIDENT COMMANDER DIRECTION

- Emergency responders should use **LARGE** amounts of water if fire is present or suspected and, keeping in mind that fire can occur for a considerable period after the crash, should proceed accordingly.
- This guide provides only supplemental information as it pertains to the Fusion Hybrid, MKZ Hybrid and Fusion Energi vehicles. The same rules apply when approaching any potential high-voltage situation. Always follow your high-voltage safety training. Some precautions to take in a high-voltage situation include:
 - Remove all jewelry: Watches, necklaces and earrings. Remove any metal objects that are conductors of electricity.
 - Wear the necessary PPEs: High-voltage rubber gloves, face shield, insulated boots, protective raincoat and apron.
- Bring the following equipment:
 - Class ABC powder-type fire extinguisher.
 - A nonconductive object, about 1.5 m (5 ft) long. This can be used to safely push someone away from the vehicle if they accidentally come in contact with high-voltage.

APPROACHING A DAMAGED HIGH-VOLTAGE VEHICLE - CONTINUED

2. APPROACHING A DAMAGED VEHICLE

- Disable the high-voltage electrical system using as many of the following steps as possible:
 - Secure the vehicle: Place the shift lever into the PARK position. Place the ignition in the OFF position to disconnect the high-voltage system. Block the wheels, if necessary.
 - Disconnect the negative cable from the 12-volt battery.
 - If possible, remove the high-voltage service disconnect(s). For additional information, refer to page 12 in this manual. If the service disconnects cannot be removed, avoid the high-voltage system components, and wear all appropriate PPE as outlined on page 13 of this guide.

- If the vehicle is on fire, use a Class ABC powder-type extinguisher to contain and smother the flames. If water is being used, **LARGE** amounts of water will be required to extinguish the flames. A fire-hydrant or dedicated fire hose can supply the needed amount. Water can cause some degree of arcing/shorting across the cell and/or battery terminals; it can also react with the electrolyte from the cells to generate additional combustible gas and other by-products such as hydrofluoric acid; however, the cooling and smothering effects of flushing the affected article with large amounts of water and/or other fire suppression material is still beneficial for minimizing the severity of the event.

- If the vehicle has any exposed cables, make sure to wear high-voltage rubber gloves and other appropriate PPE. Do not touch any broken or damaged high-voltage orange cables. Treat severed cables as if they contain high voltage.

- If the vehicle is submerged in water, varying degrees of arcing/shorting within the battery will take place. Do not touch any high-voltage components or orange cables while extricating the occupant(s). Do not remove the vehicle until you are sure the high-voltage battery is completely discharged. A submerged high-voltage battery may produce a fizzing or bubbling reaction to the water. If fizzing or bubbling is observed, the high-voltage battery will be discharged when the fizzing or bubbling has completely stopped, however, still treat it as if it was not discharged.

APPROACHING A DAMAGED VEHICLE - CONTINUED

- If the vehicle is on fire, use a Class ABC powder-type extinguisher to contain and smother the flames. If water is being used, **LARGE** amounts of water will be required to extinguish the flames. A fire-hydrant or dedicated fire hose can supply the needed amount.
- If the vehicle has any exposed cables, make sure to wear high-voltage rubber gloves and other protective clothing. Do not touch any broken or damaged high-voltage orange cables. Treat severed cables as if they contain high voltage.
- If the vehicle is submerged in water, do not touch any high-voltage components or orange cables while extricating the occupant(s). Do not remove the vehicle until you are sure the high-voltage battery is completely discharged. A submerged high-voltage battery may produce a fizzing or bubbling reaction to the water. The high-voltage battery will be discharged when the fizzing or bubbling has completely stopped, however, still treat it as if it was not discharged.

3. IF THE HIGH-VOLTAGE BATTERY CASE HAS BEEN RUPTURED

- Just like any other battery, hose the area down with **LARGE** amounts of water (ie. use a Fire Hose).

4. MOVING DAMAGED VEHICLES — WRECKER DRIVERS

- Rather than attempt to discharge a propulsion battery, an emergency responder, tow truck operator, or storage facility manager should contact experts at the vehicle manufacturer on that subject.
- If possible, remove the high-voltage service disconnect. For additional information, refer to page 11 in this manual.
- Be alert. There is potential for delayed fire with damaged lithium-ion batteries.
- Call an authorized Ford Dealer or vehicle manufacturer representative, if necessary, to determine additional steps that you should take to safely recover or transport the vehicle.
- Follow the guidelines in the Wrecker Towing Manual.
 - Front Tow: Wheel Lift (FWD)
 - Rear Tow: Wheel Lift with Dolly (FWD)
 - Flatbed: FWD and AWD

5. SPECIAL NOTE TO SALVAGE YARDS

- If a vehicle with a high-voltage battery is to be scrapped, the high-voltage battery must be disposed of following all local, state/provincial and federal guidelines.
- Operators of tow trucks and vehicle storage facilities should ensure the damaged vehicle is kept in an open area instead of inside a garage or other enclosed building.

APPROACHING A DAMAGED HIGH-VOLTAGE VEHICLE - CONTINUED

6. High Voltage System - Do Not Cut Zones

- If possible, remove the high-voltage battery service disconnect before attempting any extrication procedure. Always assume the high voltage cabling and components are powered up.
- If occupant extrication is necessary, always use caution when cutting near the vehicle high voltage system components. Do not cut any of the high voltage under vehicle or under hood cabling (all high voltage cabling is orange in color). High voltage cabling runs from the high voltage batteries under the left hand side of the vehicle to the underhood compartment. Refer to the diagram below for no cut zones in orange.

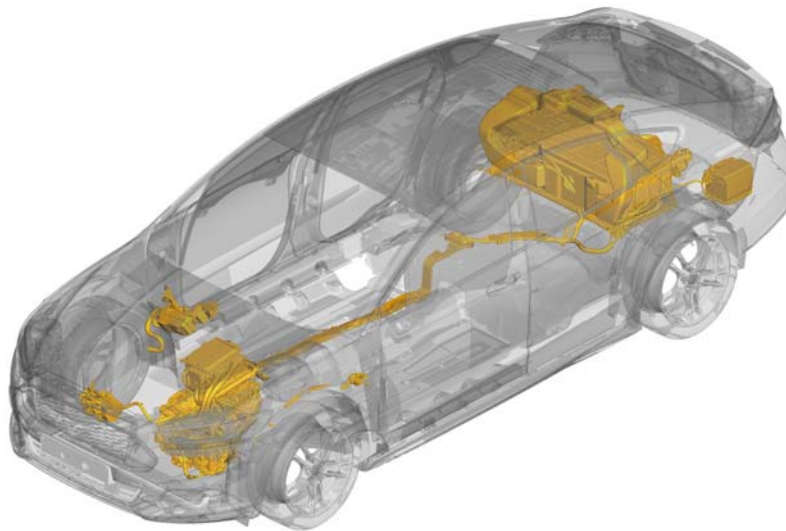
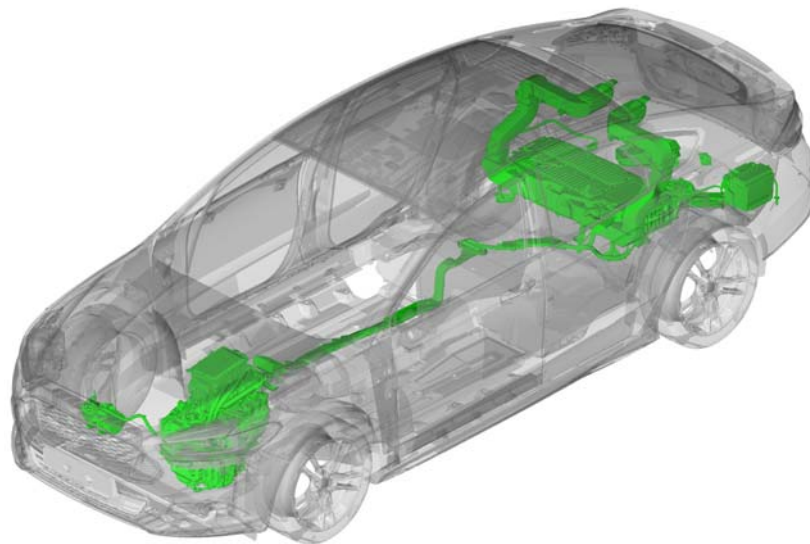

DAMAGED VEHICLE GUIDANCE FOR FORD MOTOR COMPANY ELECTRIC AND HYBRID-ELECTRIC VEHICLES EQUIPPED WITH HIGH-VOLTAGE BATTERIES (TOWING, RECOVERY OPERATORS AND VEHICLE STORAGE FACILITIES)

For questions contact Ford USA 1-800-392-3673 / Ford Canada 1-800-565-3673

1. In the event of damage to or fire involving an Electric Vehicle (EV) or Hybrid Electric Vehicle (HEV).

- Always assume the high-voltage (HV) battery and associated components are energized and fully charged.
- Exposed electrical components, wires, and HV batteries present potential HV shock hazards.
- Venting/off-gassing HV battery vapors are potentially toxic and flammable.
- Physical damage to the vehicle or HV battery may result in immediate or delayed release of toxic and/or flammable gases and fire.

2. Vehicle Shutdown and High-Voltage System Disabling

Identify Vehicle

- Determine if the vehicle is an electric or hybrid-electric vehicle, and if it is, advise your dispatch and all other responders that an electric or hybrid-electric vehicle is involved.
- To identify potential symptoms of a damaged high-voltage system, contact an authorized service center or vehicle manufacturer representative. Refer to the Vehicle Owner Manual, Emergency Placard (included in the Vehicle Owner Manual) and/or the Emergency Response Guide for appropriate contact information.
- If you detect leaking fluids, sparks, smoke, flames, increased temperature, gurgling, popping or hissing noises from the HV battery compartment, ventilate the passenger area (i.e., roll down windows or open doors) and call 911.
- Be alert. There is a potential for delayed fire with damaged lithium-ion batteries.

DAMAGED VEHICLE GUIDANCE FOR FORD MOTOR COMPANY ELECTRIC AND HYBRID-ELECTRIC VEHICLES EQUIPPED WITH HIGH-VOLTAGE BATTERIES (TOWING, RECOVERY OPERATORS AND VEHICLE STORAGE FACILITIES) - CONTINUED

3. Recovering/Transporting Vehicle

- Call an authorized service center or vehicle manufacturer representative, if necessary, to determine additional steps that you should take to safely recover or transport the vehicle.
- Always approach the vehicle from the sides to stay out of potential travel path. It may be difficult to determine if the vehicle is running due to lack of engine noise.
- Refer to vehicle manual/recovery guide to locate proper attachment/connection points and transport method.
- Avoid contact with orange high-voltage cabling and areas identified as high-voltage risk by warning labels.

4. Storing Vehicle

- **For vehicles in the United States, notify Ford Motor Company 1-800-392-3673 (then follow the prompts on the voice response menu) or an authorized Ford Dealer as soon as possible. There may be additional steps necessary to secure, discharge, handle and/or store the HV battery and vehicle.**
- **For vehicles in Canada, notify Ford Motor Company 1-800-565-3673 (then follow the prompts on the voice response menu), or an authorized Ford dealer as soon as possible. There may be additional steps necessary to secure, discharge, handle, and/or store the HV battery and vehicle.**
- Do not store a severely damaged vehicle with a lithium-ion battery inside a structure or within 50 feet of any structure or vehicle.
- Ensure that passenger and cargo compartments remain ventilated.
- Prior to placing and while located in storage area/tow lot, continue to inspect vehicle for leaking fluids, sparks, smoke, flames, gurgling or bubbling sounds from the HV battery and call 911 if any of these are detected.
- Maintain clear access to stored vehicles for monitoring and emergency response if needed.

For specific information and safety preparation regarding the high-voltage system, refer to WWW.MOTORCRAFTSERVICE.COM, select quick guides for the appropriate vehicle emergency response guide.

 **WARNING:** ELECTRIC VEHICLES DAMAGED BY A CRASH MAY HAVE COMPROMISED HIGH-VOLTAGE SAFETY SYSTEMS AND PRESENT A POTENTIAL HIGH-VOLTAGE ELECTRICAL SHOCK HAZARD. EXERCISE CAUTION AND WEAR APPROPRIATE PERSONAL PROTECTIVE EQUIPMENT (PPE) SAFETY GEAR, INCLUDING HIGH-VOLTAGE SAFETY GLOVES AND BOOTS. REMOVE ALL METALLIC JEWELRY, INCLUDING WATCHES AND RINGS. ISOLATE THE HV SYSTEM AS DIRECTED BY THE FORD EMERGENCY RESPONSE GUIDE FOR THE VEHICLE. FAILURE TO FOLLOW THESE INSTRUCTIONS MAY RESULT IN SERIOUS PERSONAL INJURY OR DEATH.

 **WARNING:** DAMAGED ELECTRIC VEHICLES SUBMERGED IN WATER PRESENT A POTENTIAL HIGH VOLTAGE ELECTRICAL SHOCK HAZARD. EXERCISE CAUTION AND WEAR APPROPRIATE PERSONAL PROTECTIVE EQUIPMENT (PPE) SAFETY GEAR, INCLUDING HIGH VOLTAGE SAFETY GLOVES AND BOOTS. REMOVE ALL METALLIC JEWELRY, INCLUDING WATCHES AND RINGS. DO NOT ATTEMPT TO EXTRACT THE VEHICLE UNTIL THE HIGH VOLTAGE BATTERY HAS DISCHARGED INDICATED BY THE ABSENCE OF BUBBLING OR FIZZING. FAILURE TO FOLLOW THESE INSTRUCTIONS MAY RESULT IN SERIOUS PERSONAL INJURY OR DEATH.

 **WARNING:** FIRES IN CRASH-DAMAGED ELECTRIC VEHICLES MAY EMIT TOXIC OR COMBUSTIBLE GASSES. SMALL AMOUNTS OF EYE, SKIN OR LUNG IRRITANTS MAY BE PRESENT. WEAR PERSONAL PROTECTIVE EQUIPMENT (PPE) AND SELF-CONTAINED BREATHING APPARATUS WHEN WORKING IN CLOSE PROXIMITY OR IN A CONFINED AREA, SUCH AS A TUNNEL OR GARAGE. VENTILATE THE VEHICLE INTERIOR BY OPENING VEHICLE WINDOWS OR DOORS. VENTILATE THE WORKING AREA. FAILURE TO FOLLOW THIS INSTRUCTION MAY RESULT IN SERIOUS PERSONAL INJURY OR DEATH.

 **WARNING:** ELECTRIC VEHICLES WITH DAMAGED HIGH VOLTAGE BATTERIES REQUIRE SPECIAL HANDLING PRECAUTIONS. INSPECT THE VEHICLE CAREFULLY FOR LEAKING BATTERY FLUIDS, SPARKS, FLAMES, AND GURGLING OR BUBBLING SOUNDS. CONTACT EMERGENCY SERVICES IMMEDIATELY IF ANY OF THESE PROBLEMS ARE OBSERVED. FAILURE TO FOLLOW THESE INSTRUCTIONS MAY RESULT IN A VEHICLE FIRE AND PERSONAL INJURY OR DEATH.

High Voltage Battery - Removal

⚠ WARNING: TO PREVENT THE RISK OF HIGH-VOLTAGE SHOCK, ALWAYS FOLLOW PRECISELY ALL WARNINGS AND SERVICE INSTRUCTIONS, INCLUDING INSTRUCTIONS TO DEPOWER THE SYSTEM. THE HIGH-VOLTAGE SYSTEM UTILIZES APPROXIMATELY 325 VOLTS DC, PROVIDED THROUGH HIGH-VOLTAGE CABLES TO ITS COMPONENTS AND MODULES. THE HIGH-VOLTAGE CABLES AND WIRING ARE IDENTIFIED BY ORANGE HARNESS TAPE OR ORANGE WIRE COVERING. ALL HIGH-VOLTAGE COMPONENTS ARE MARKED WITH HIGH-VOLTAGE WARNING LABELS WITH A HIGH-VOLTAGE SYMBOL. FAILURE TO FOLLOW THESE INSTRUCTIONS MAY RESULT IN SERIOUS PERSONAL INJURY OR DEATH.

1. Depower the high-voltage (HV) batteries. Refer to the high-voltage service disconnects on page 11.

NOTE: Wait 5 minutes after the service disconnect plug is removed before continuing service. This allows any residual voltage in the high voltage system to dissipate.

NOTE: Depowering the high-voltage system **does not** dissipate the high-voltage inside the battery. The battery pack will remain live and dangerous.

NOTE: Fusion Hybrid shown, MKZ Hybrid and Fusion Energi similar.

2. Disconnect and isolate the negative battery cable.

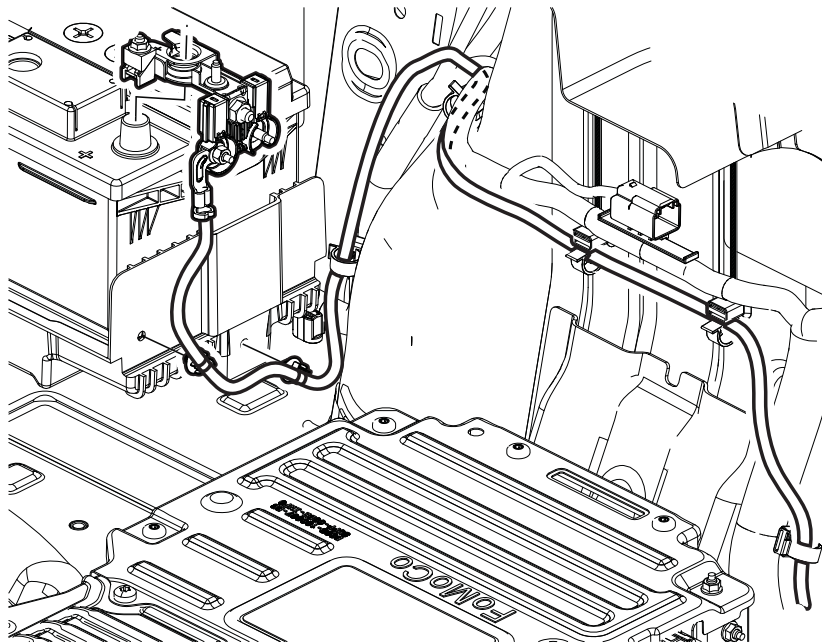

NOTE: Fusion Hybrid shown, MKZ Hybrid and Fusion Energi similar.

3. Remove the rear seat cushion from the vehicle.

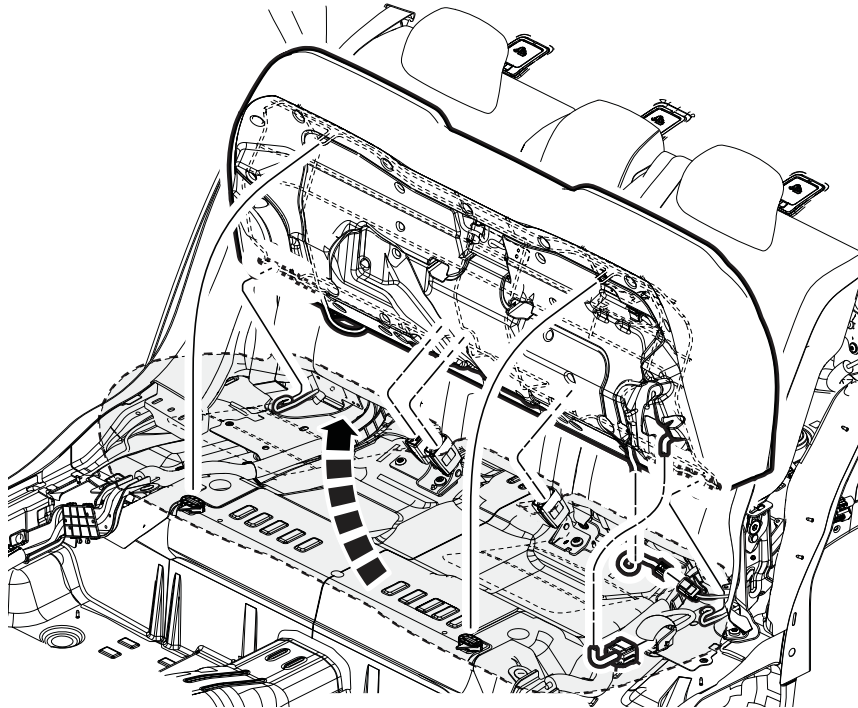

NOTE: Fusion Hybrid shown, MKZ Hybrid and Fusion Energi similar.

4. Remove the 40% Seat Back:

- A. Disengage and tilt seat back forward.
- B. Disengage seat back at the hinge.
- C. Pull seat back towards the passenger side and remove.

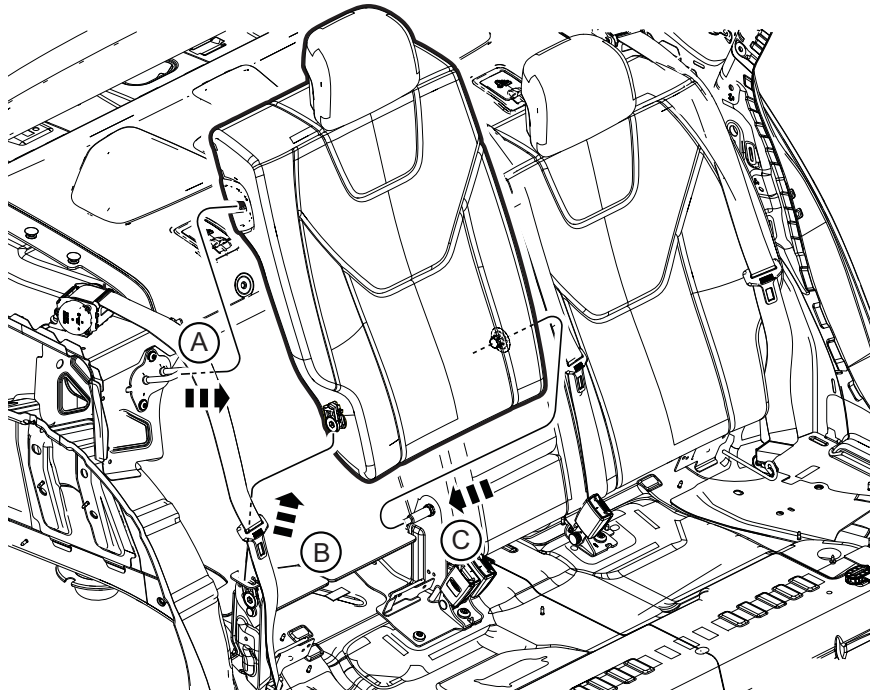

NOTE: Fusion Hybrid shown, MKZ Hybrid and Fusion Energi similar.

5. Remove the 60% Seat Back:

- A. Remove the seat belt anchor plate fastener.
- B. Disengage and tilt seat back forward.
- C. Disengage seat back at hinge.
- D. Pull seat back towards the driver side and remove.

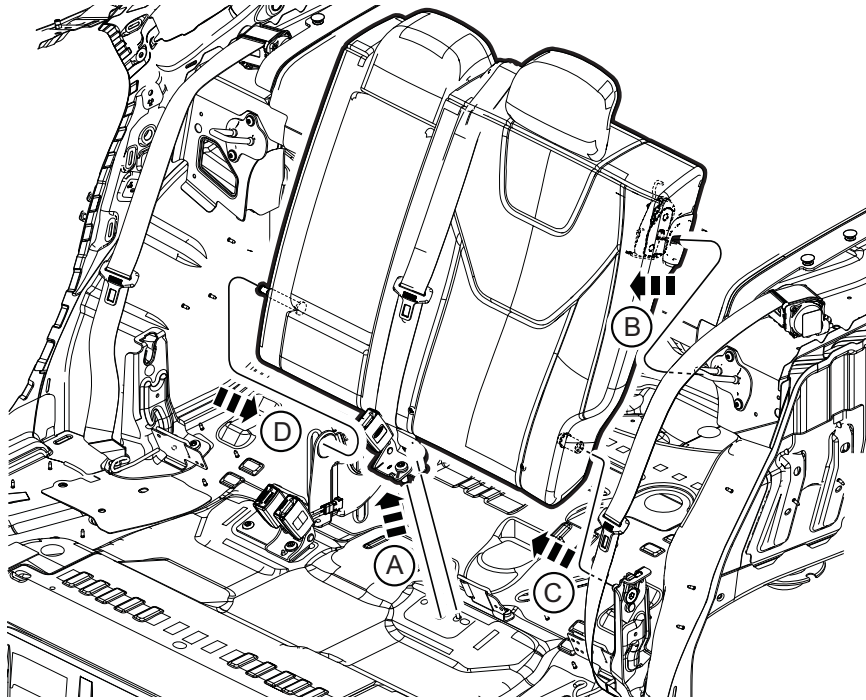

NOTE: Fusion Hybrid shown, MKZ Hybrid and Fusion Energi similar.

6. Remove the cargo cover from the trunk compartment.

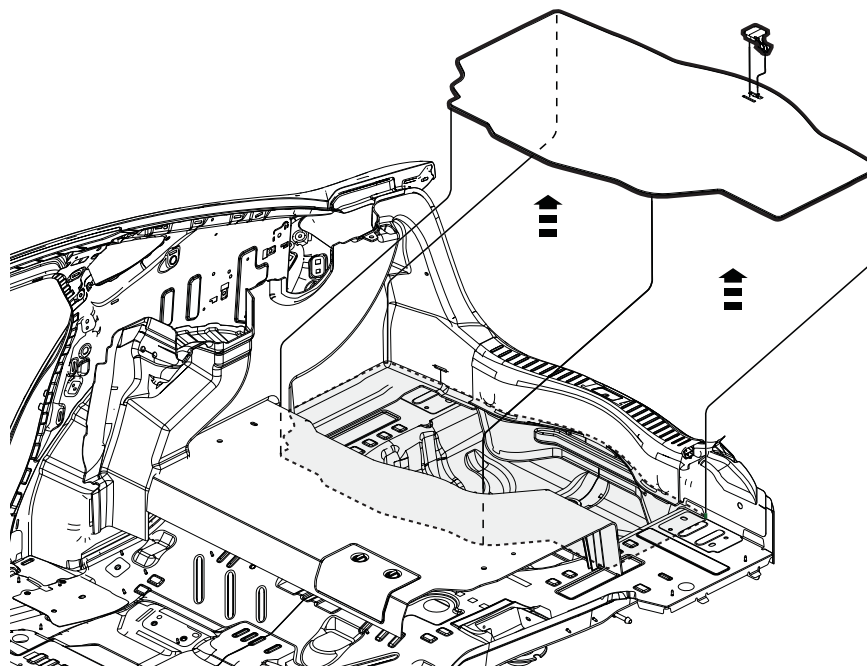

NOTE: Fusion Hybrid shown, MKZ Hybrid and Fusion Energi similar.

7. Remove the trunk scuff.

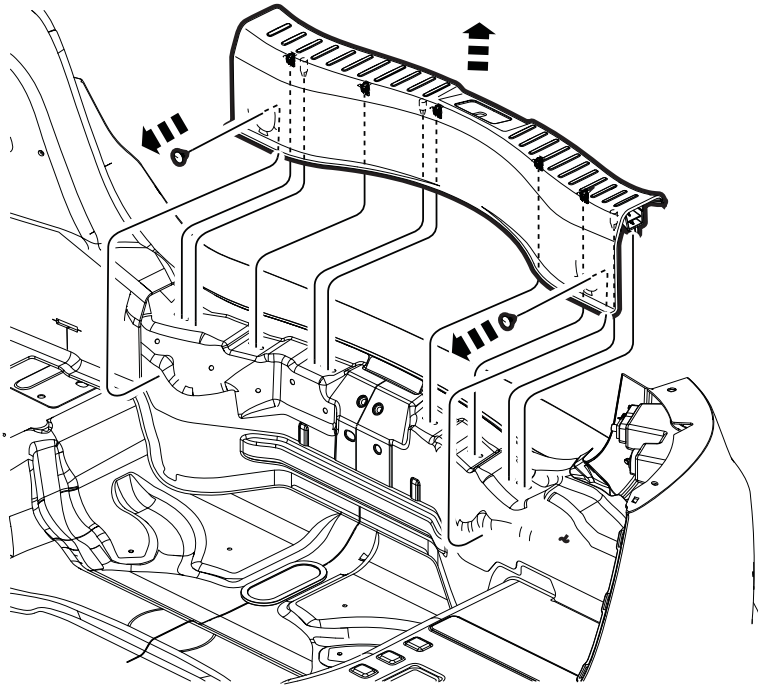

NOTE: Fusion Energi vehicles only.

8. Remove the auxiliary charge plug tool box from the cargo area.

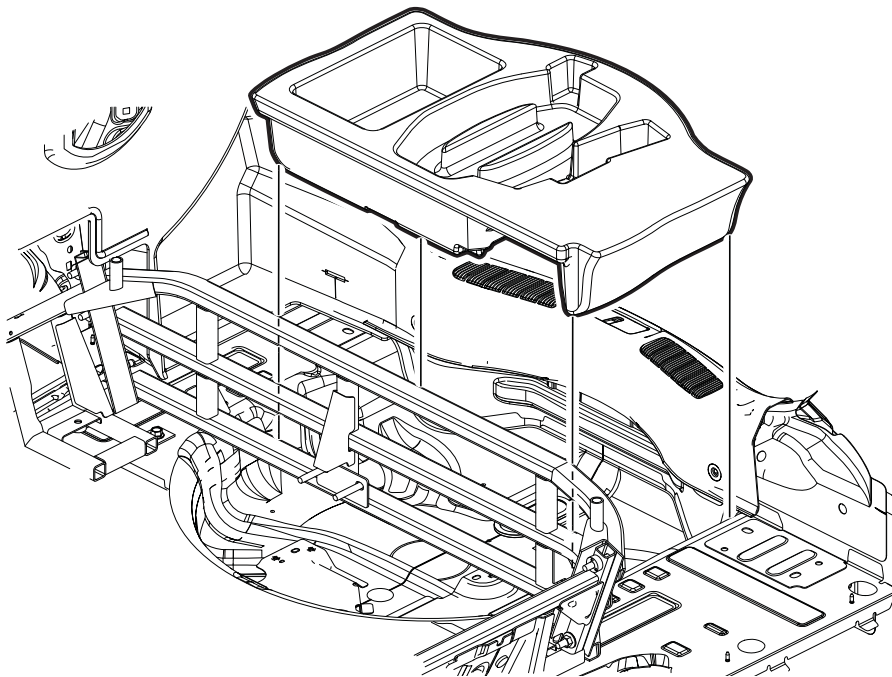

NOTE: Fusion Hybrid and MKZ Hybrid vehicles.

9. Remove the battery cover.

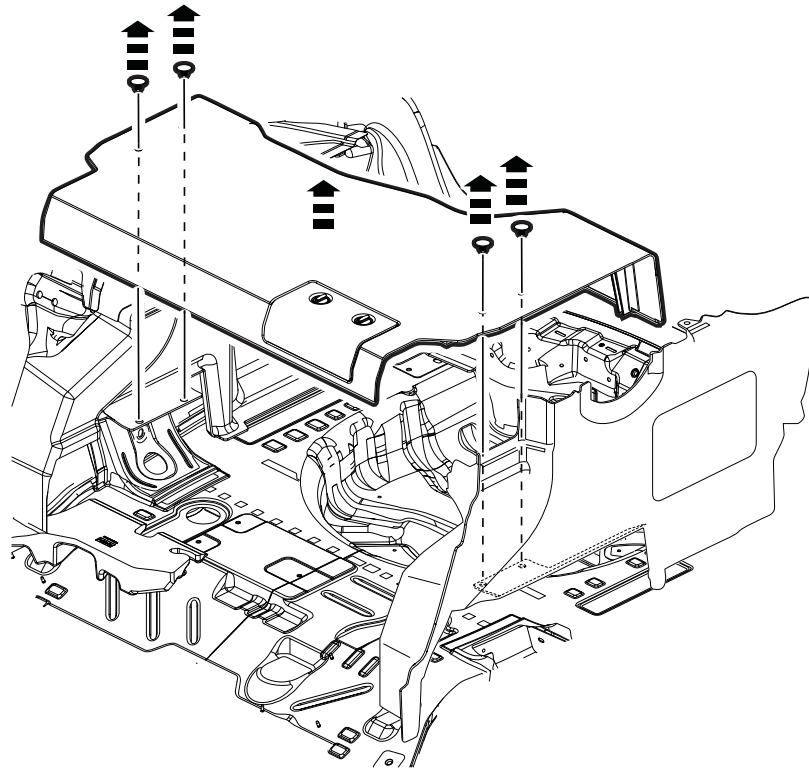

NOTE: Fusion Energi vehicles.

10. Remove the front battery cover.

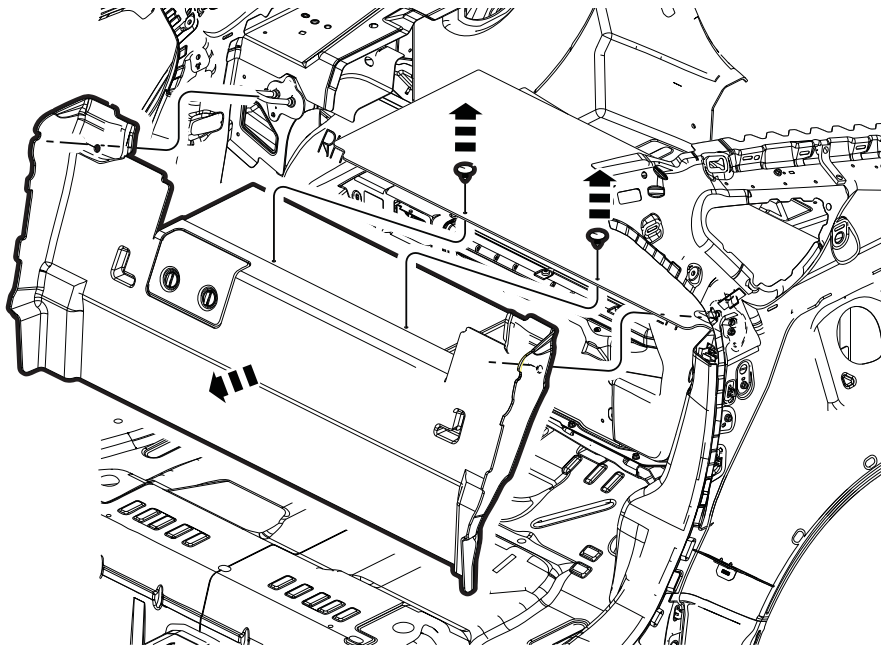

NOTE: Fusion Energi vehicles.

11. Remove the rear battery cover.

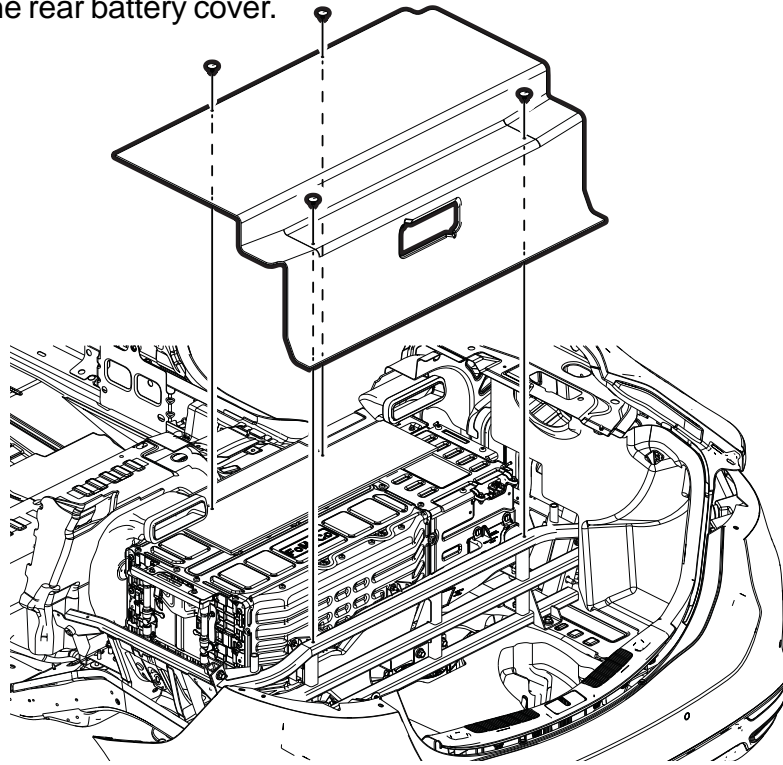

NOTE: Fusion Energi vehicles.

12. Remove the rear battery protector.

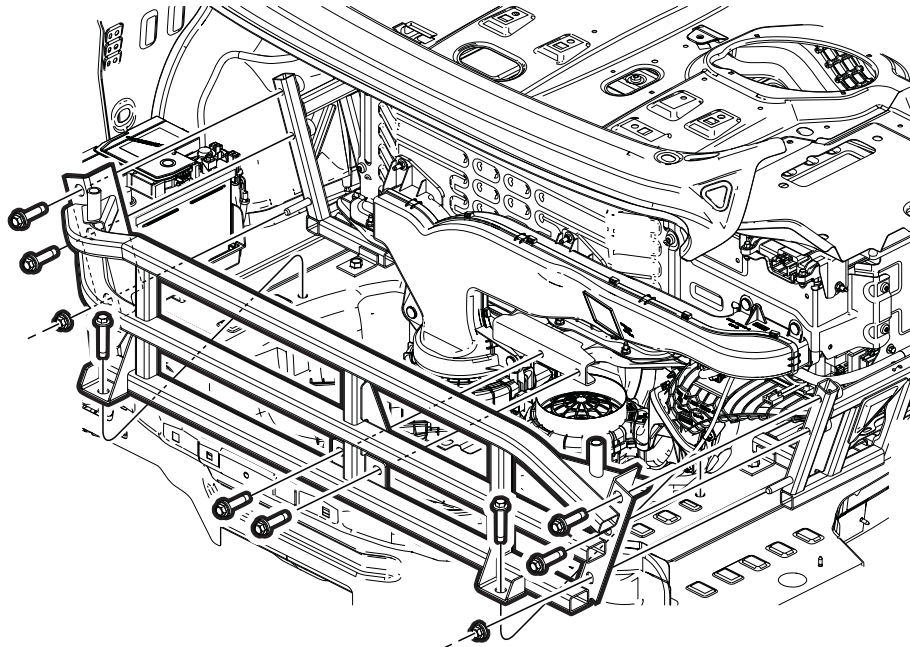

NOTE: Fusion Hybrid and MKZ Hybrid vehicles.

13. Disconnect and remove the traction battery fan.

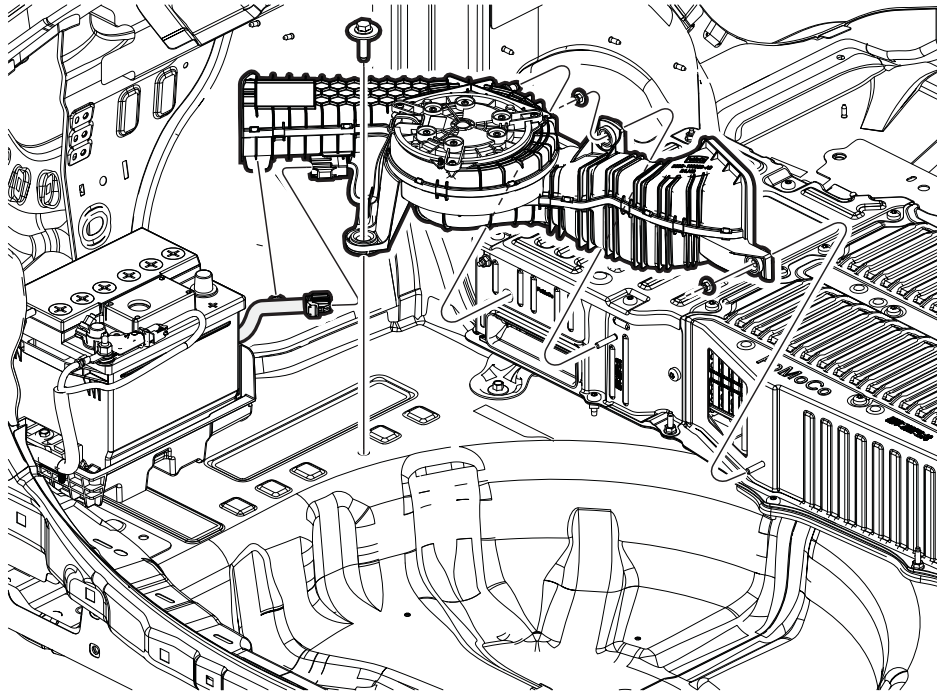

NOTE: Fusion Energi vehicles only.

14. Remove the traction battery outlet vent.

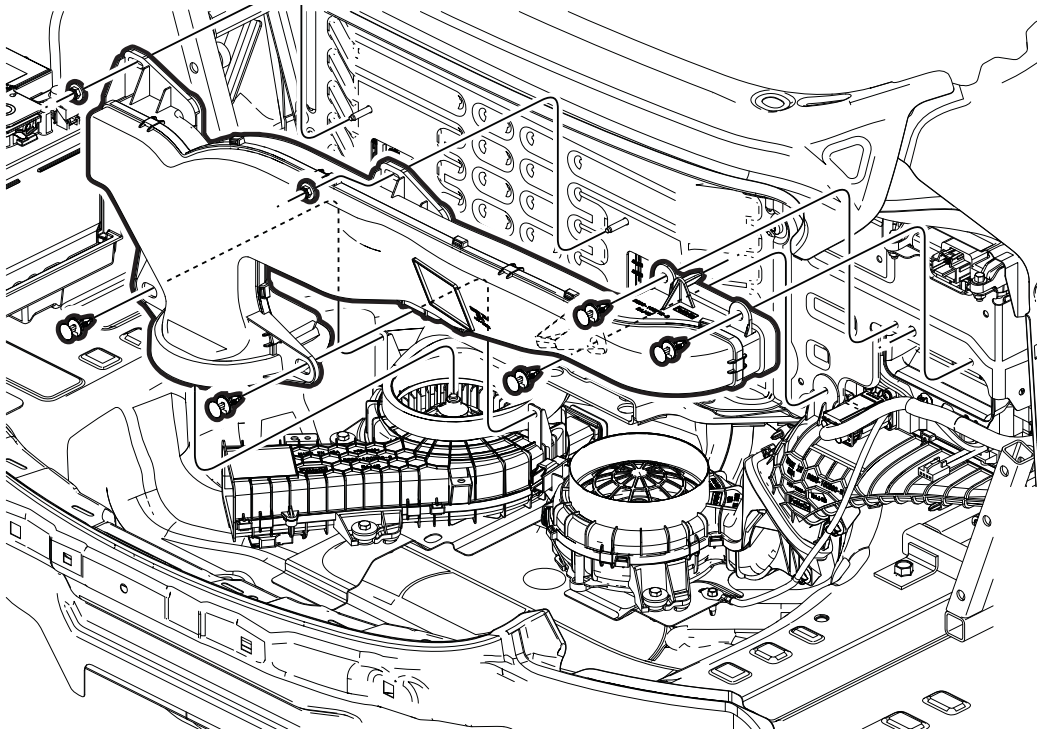

NOTE: Fusion Energi vehicles only.

15. Remove the traction battery inlet vent from the fan.

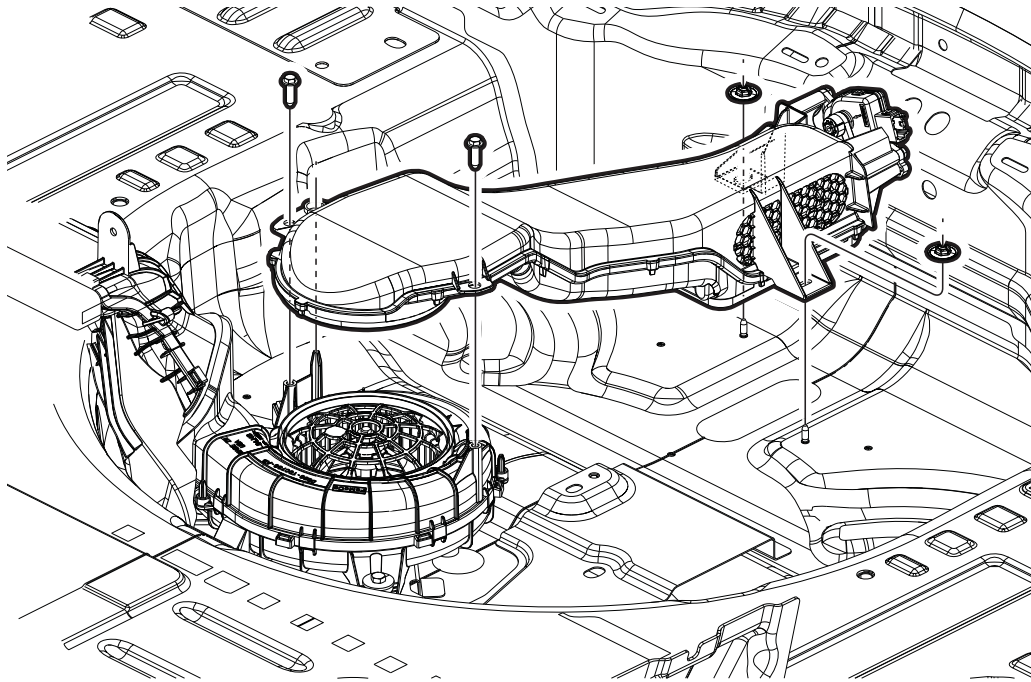

NOTE: Fusion Energi vehicles only.

16. Disconnect and remove the traction battery inlet fan.

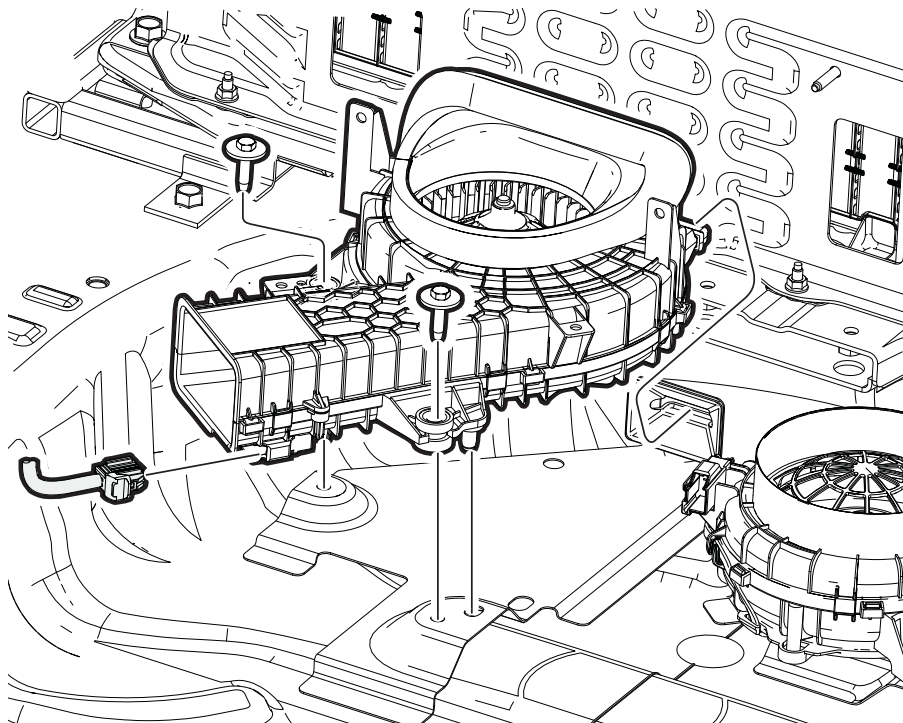

NOTE: Fusion Energi vehicles only.

19. Disconnect and remove the traction battery outlet fan.

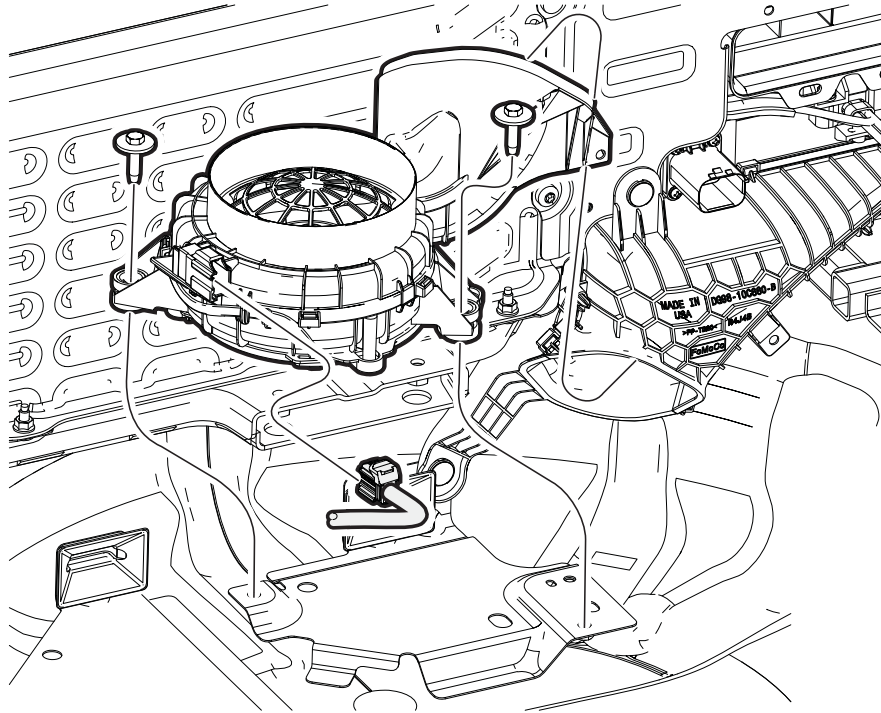

NOTE: Fusion Energi vehicles only.

20. Disconnect and remove the traction battery outlet vent.

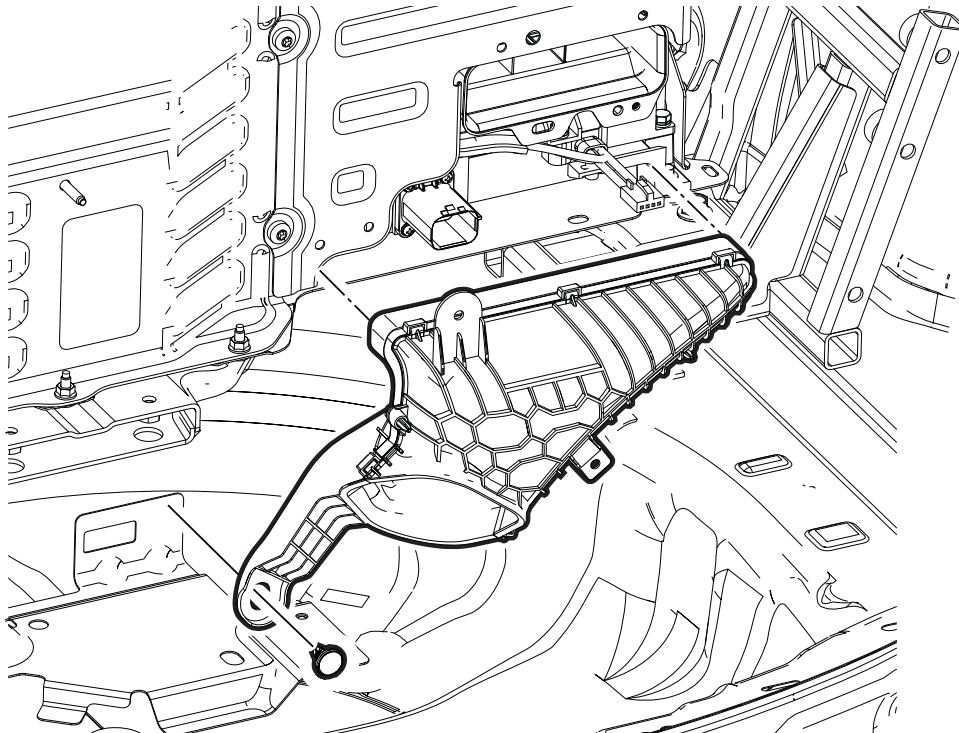

NOTE: Fusion Hybrid shown, MKZ Hybrid and Fusion Energi similar.

21. Remove the vent from the 12V battery located in the cargo area on the driver side.

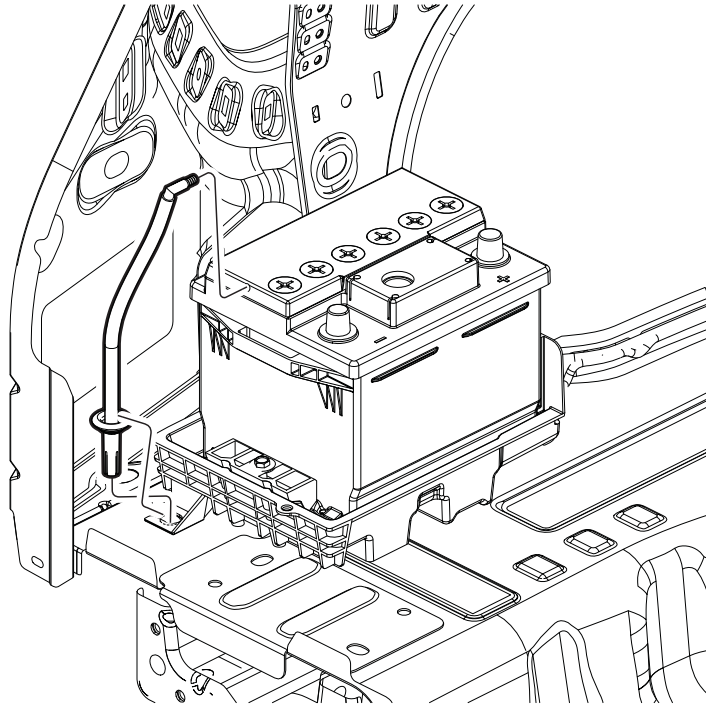

NOTE: Fusion Hybrid shown, MKZ Hybrid and Fusion Energi similar.

22. Remove the 12V battery located in the cargo area on the driver side.

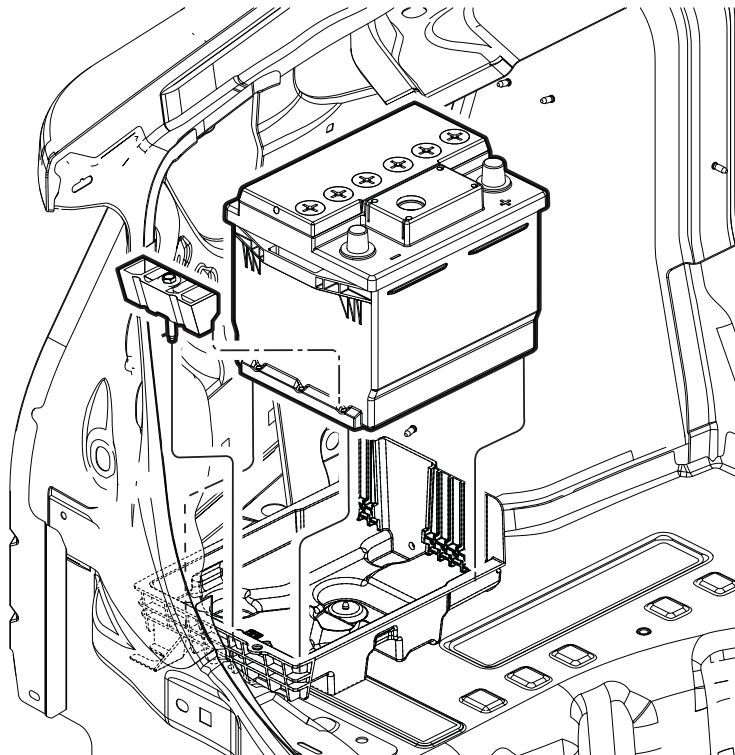

NOTE: Fusion Energi vehicles only.

24. Remove the LH traction battery inlet vent.

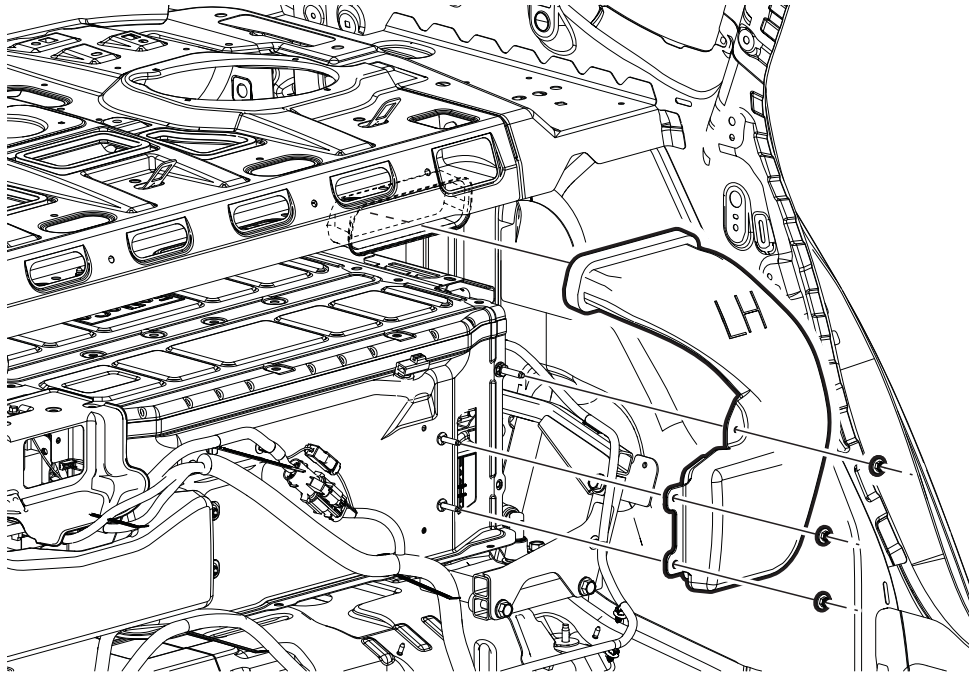

NOTE: Fusion Energi vehicles only.

25. Remove the RH traction battery inlet vent.

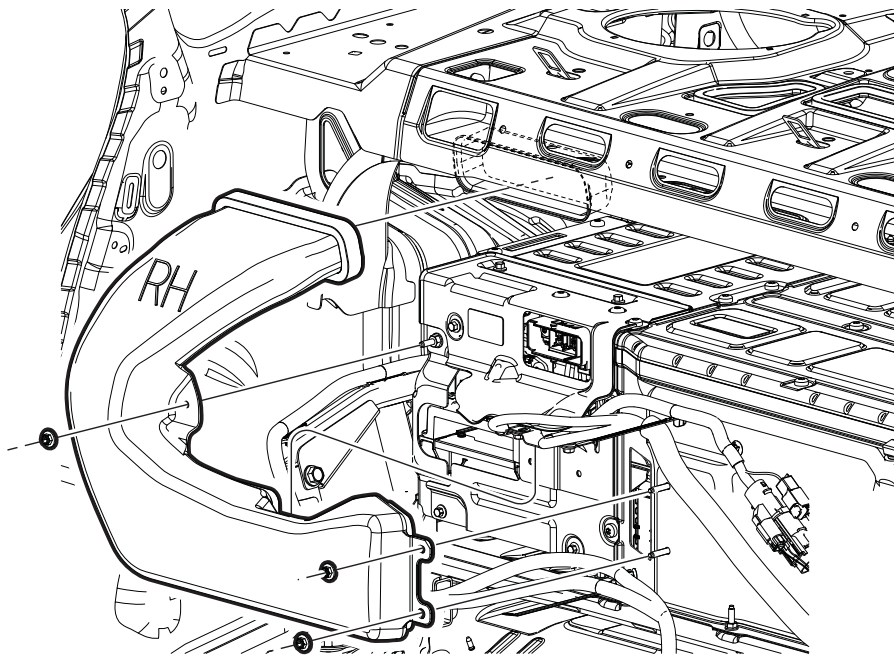

NOTE: Fusion Hybrid and MKZ Hybrid vehicles.

NOTE: LH shown, RH similar.

26. Remove the LH and RH traction battery outlet vents.

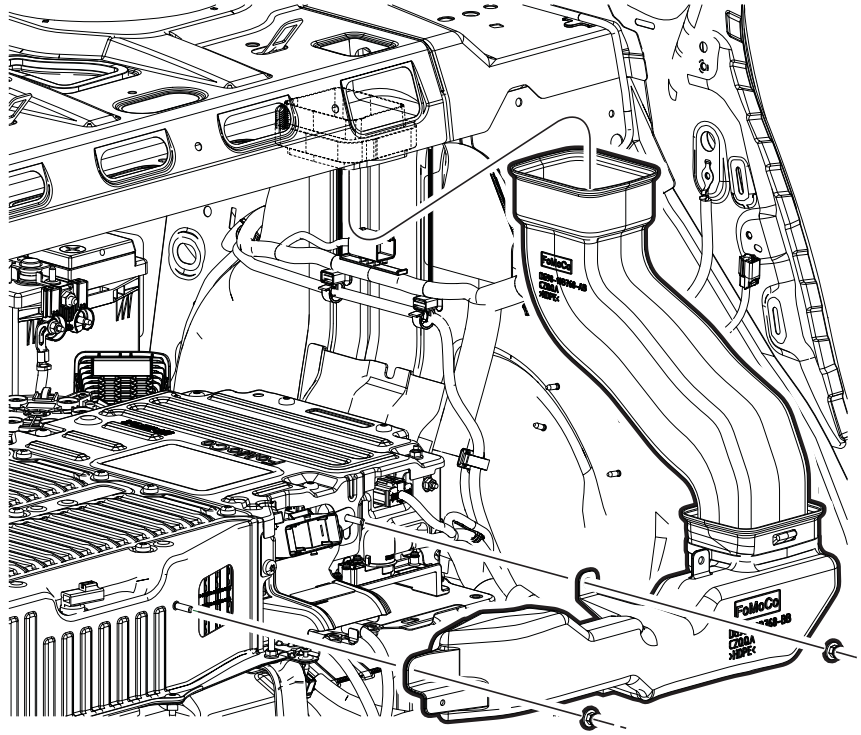

NOTE: Fusion Energi vehicles only.

27. Remove the traction battery wiring cover.

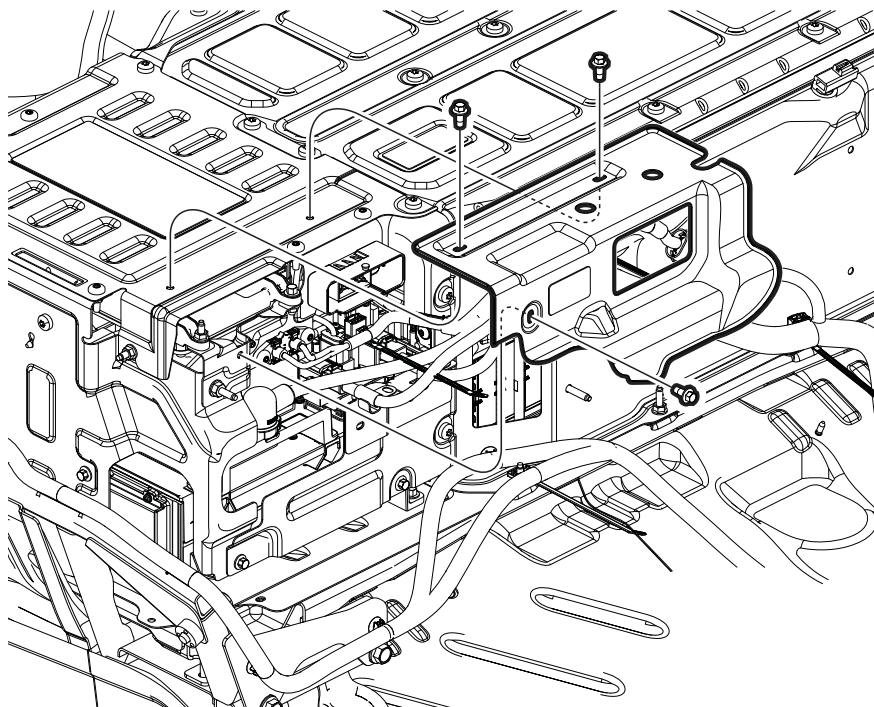

NOTE: Fusion Hybrid and MKZ Hybrid vehicles.

28. Remove the Traction Battery wiring cover.

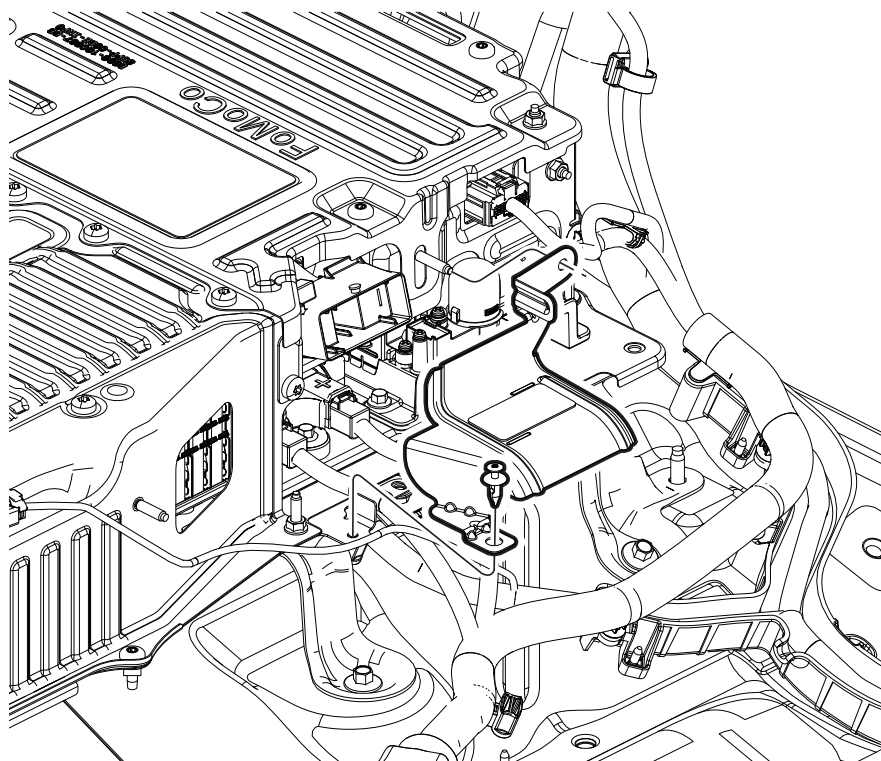

NOTE: Fusion Hybrid and MKZ Hybrid vehicles.

29. Disconnect the traction battery wiring at the battery and reposition.

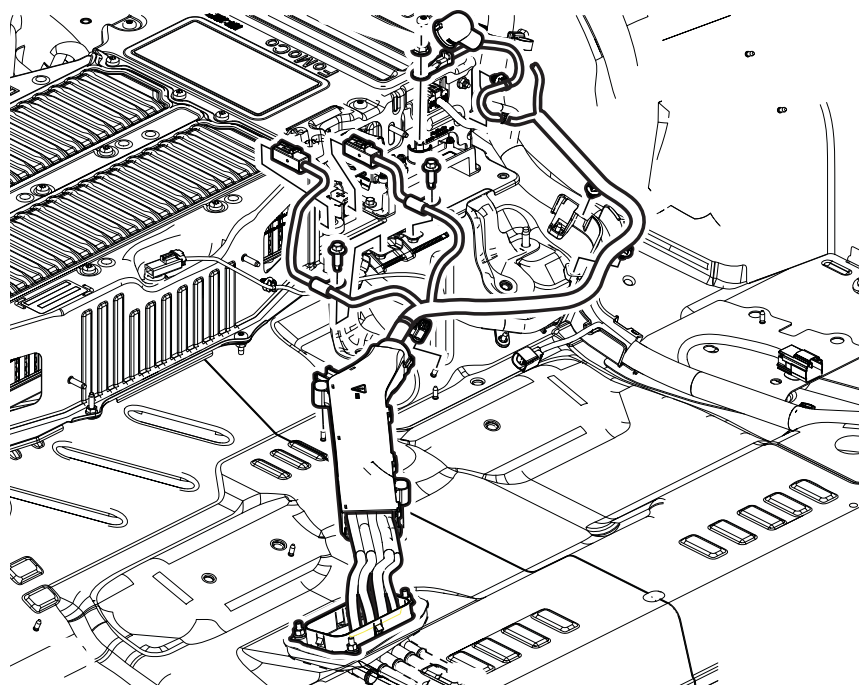

NOTE: Fusion Energi vehicles only.

30. Disconnect the traction battery wiring located at the rear of the battery on the passenger side and reposition..

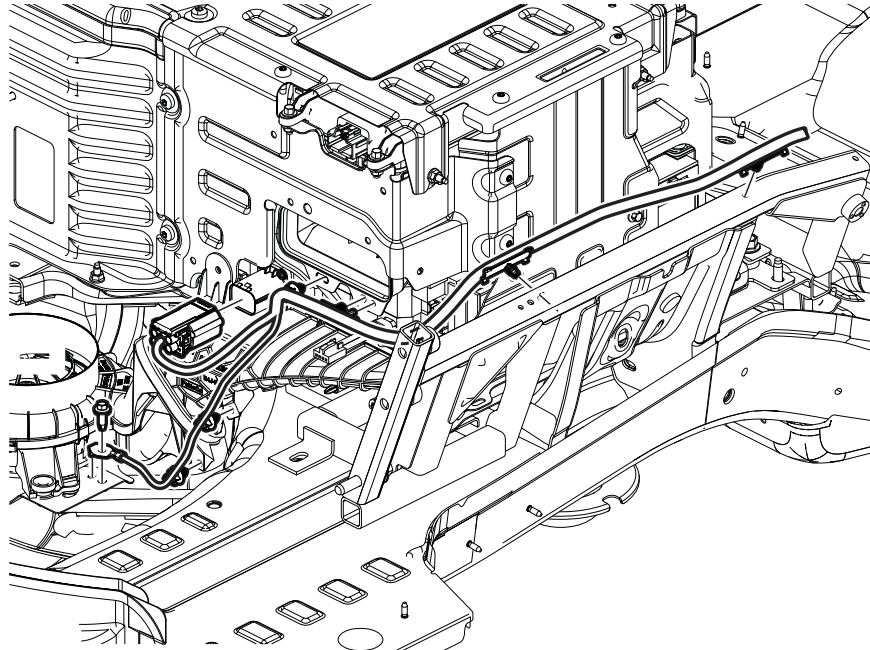

NOTE: Fusion Energi vehicles only.

31. Disconnect the traction battery wiring at the front of the battery on the passenger side and reposition.

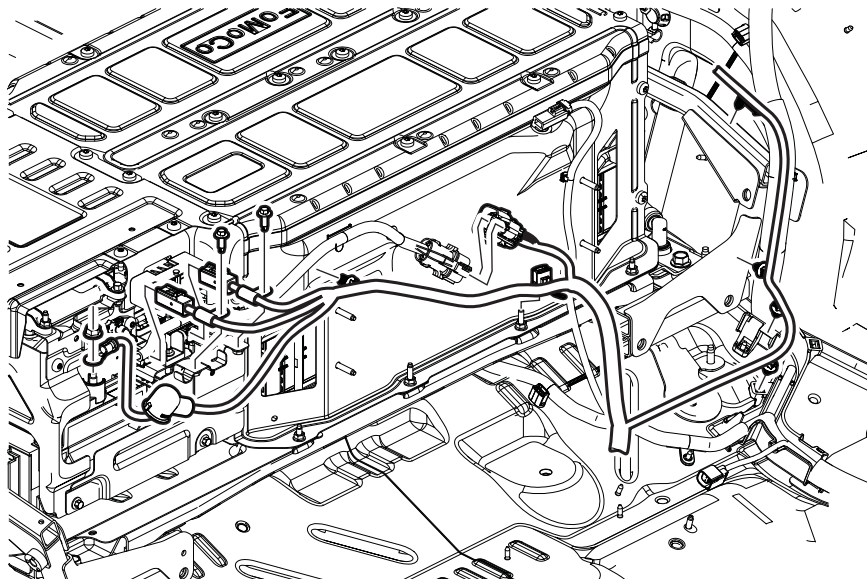

NOTE: Fusion Energi vehicles only.

NOTE: LH shown, RH similar.

32. Remove the front battery protector on both sides.

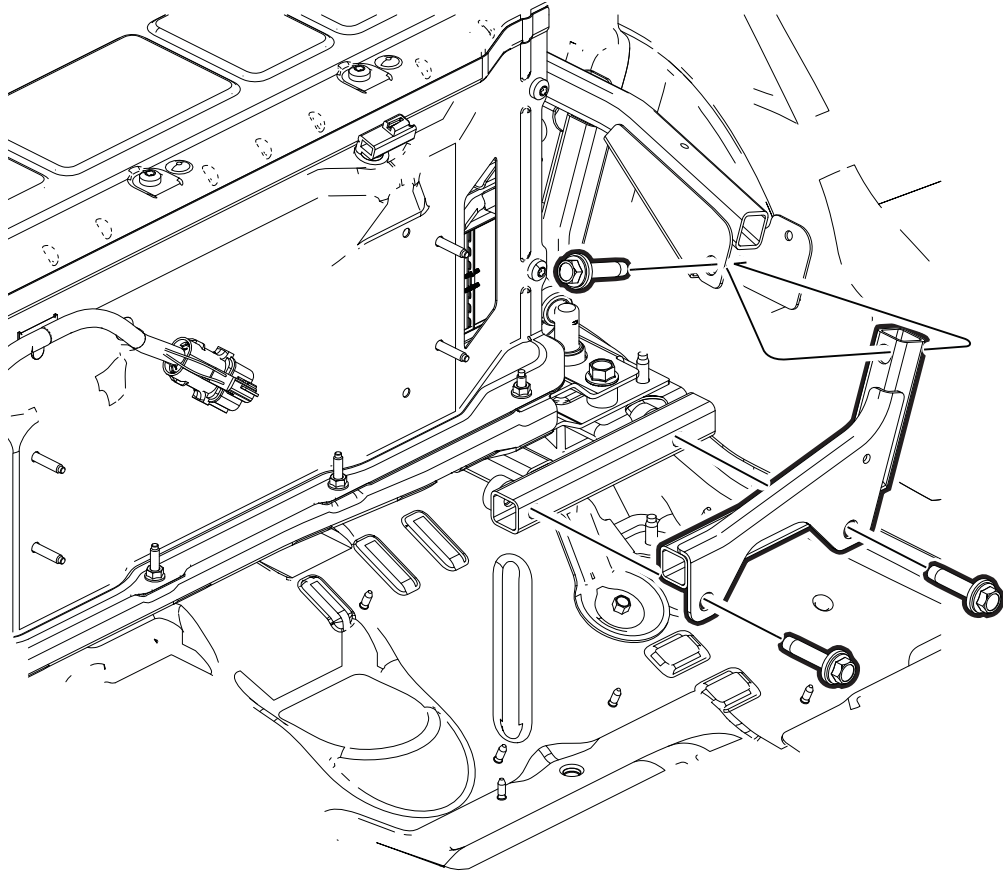

NOTE: Fusion Hybrid and MKZ Hybrid vehicles.

33. Remove the five fasteners securing the traction battery to the floor pan.
34. With the help of an assistant, lift the traction battery and remove through the cargo/trunk area.

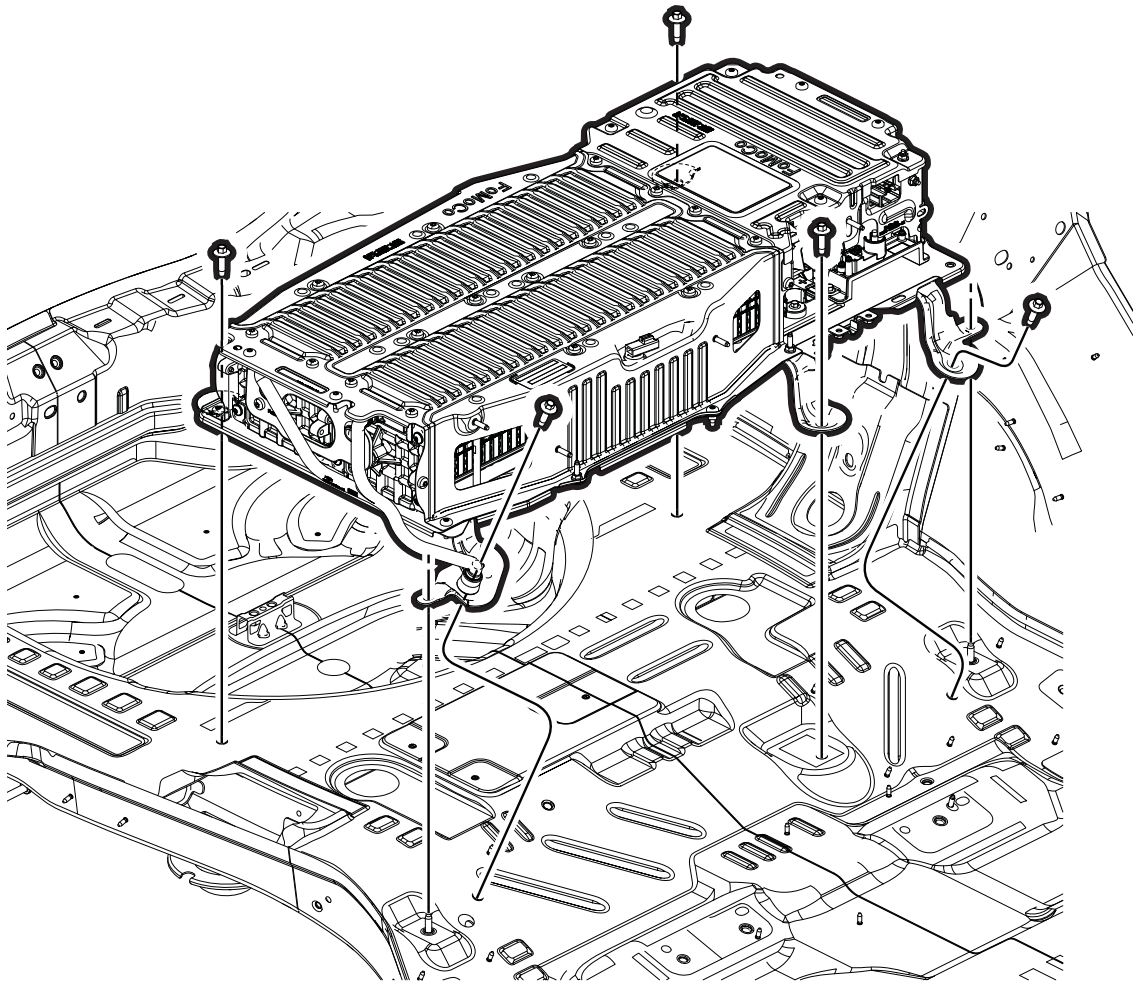

NOTE: Fusion Energi vehicles only.

35. Remove the five fasteners securing the traction battery to the floor pan.

NOTE: Removing the battery will require three people.

36. With the help of two assistants, lift the traction battery, position forward towards the front of the vehicle and remove through the rear door opening.

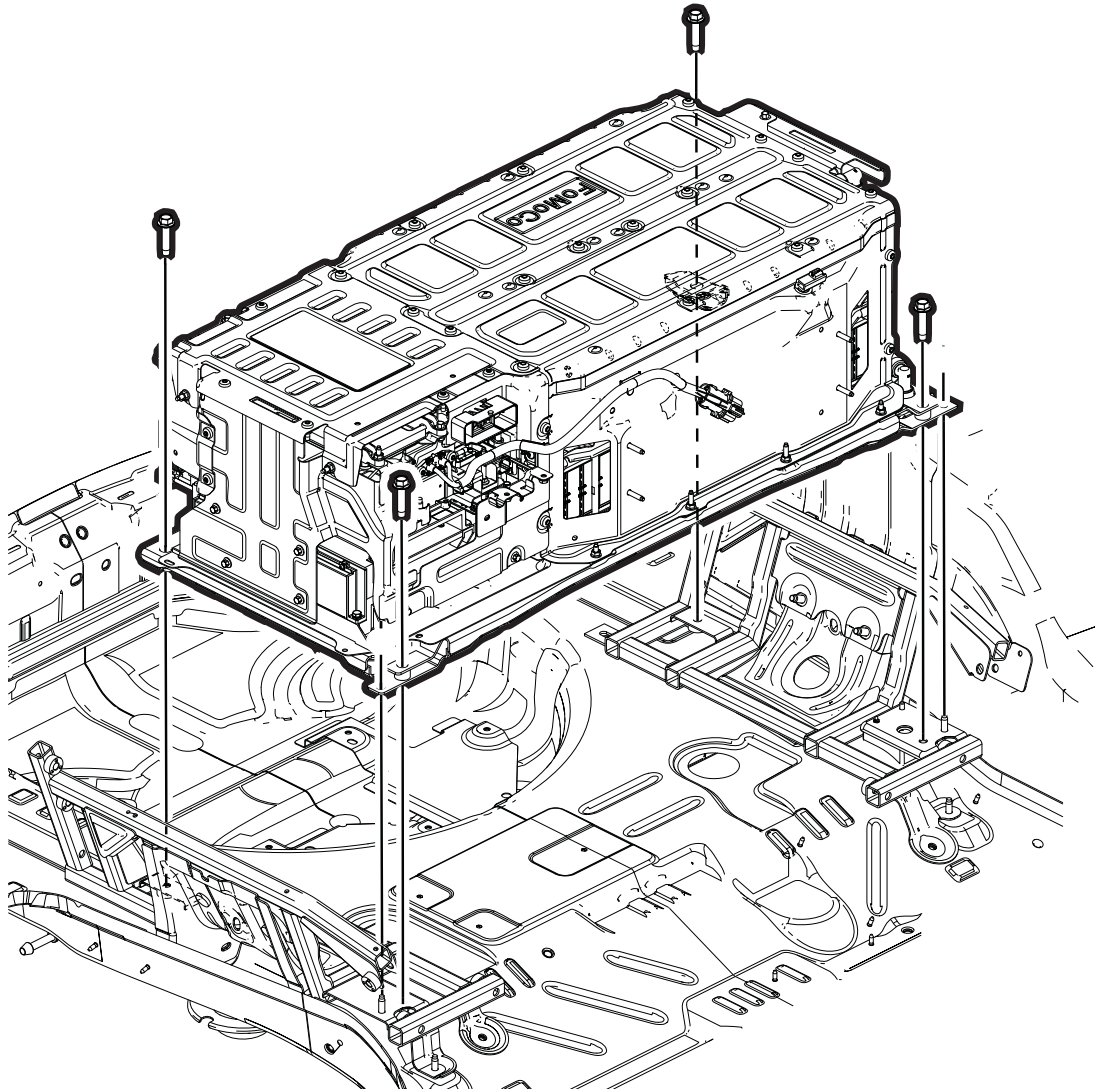

SPECIAL NOTE TO SALVAGE YARDS

If a vehicle with a high-voltage battery is to be scrapped, the high-voltage battery must be disposed of following all local, state/provincial and federal guidelines.

The Fusion Hybrid, MKZ Hybrid and Fusion Energi vehicles' Lithium-Ion high-voltage battery pack (Li-Ion HVB) is fully recyclable and should be shipped to a permitted recycling facility. The guidelines below are for Li-Ion HVBs which have been removed from the vehicle and discharged.

General Guidelines

Once the battery has been removed from the vehicle and discharged:

1. Store the battery's components in a building or under shelter so that batteries are kept dry and not exposed to high temperatures.
2. Protect battery's components from being damaged (e.g. crushed or punctured).
3. It is recommended to ask about the specific packaging requirements for battery shipments to the recycler who will be receiving the battery components in order to avoid inappropriate repacking/stacking of the batteries.
4. Batteries should be sorted by type. Keep lead acid batteries, NiMH batteries, and Li-Ion batteries separated from each other (e.g. separate pallets or storage locations).

Applicable Laws/Regulations

The following is a general explanation of certain applicable laws; however, these laws change from time to time, additional regulations are under development and Ford Motor Company makes no representation that this is a complete summary.

Packaging and Transport

The U.S. Department of Transportation (DOT) outlines packaging and shipping requirements for Li-Ion batteries. Certain exceptions on packaging and transportation regulations for large format Li-Ion batteries may be found in 49CFR 173.185 (d) and (g).

Make sure that the shipping paperwork is filled out correctly and that the shipment is properly labeled per federal, state, and local laws and regulations.

Check to make sure that you are complying with any recordkeeping requirements. Only certified hazardous material shippers should offer transport of a hazardous material.

Generally, under U.S. DOT regulations, Li-Ion batteries are usually considered a dangerous good and regulated as hazardous materials when transported. Li-Ion batteries are classified as Class 9 hazardous material.

Batteries for recycling should be shipped by ground or vessel only. Do not ship batteries for recycling by air.

SPECIAL NOTE TO SALVAGE YARDS - CONTINUED

NOTE: A damaged battery (one that is leaking electrolyte from the battery pack) might need to be shipped as a hazardous waste. Check your yellow pages (e.g. waste, rubbish and garbage removal, recyclables, recycling) to locate a company that specializes in transporting or managing hazardous wastes.

Recycling

40 CFR 261 states that manufactured articles that yield extracts which exceed one or more of the concentration limits of regulated listed constituents, or meets the definition of ignitability, corrosivity or reactivity are defined as hazardous wastes and must be disposed of in accordance with federal and state regulations. Since there are many variations in the specific chemistry of Li-Ion batteries, additional classifications may be necessary and is the responsibility of the generator. Generally, under federal and state law, sealed, Li-Ion batteries may be considered dry cell batteries and therefore may be managed as a universal waste; damaged or leaking Li-Ion batteries may be regulated as hazardous waste under federal and state regulations.

Though Ford Motor Company makes no representations or endorsements, there are companies that have the capability to accept, consolidate and recycle Li-Ion HVBs, and a few are listed below. Contact the appropriate battery manufacturer for additional information.

North America Battery Recyclers

Kinsbursky Brothers, Inc.

125 E. Commercial
Anaheim, CA 92801
Phone: 714-738-8516
Fax: 714-773-4830

TOXCO Inc.

265 Quarry Road
Lancaster, OH 43130
Phone: 877-461-2345
Fax: 740-653-3240

TOXCO Inc.

9384 Highway 22A
P.O. Box 232
Trail, B.C. Canada V1R 4L5
Phone: 877-GOTOXCO (877) 468-6929
Fax: 250-367-9875